



# basic education

Department:  
Basic Education  
REPUBLIC OF SOUTH AFRICA

## NATIONAL SENIOR CERTIFICATE NASIONALE SENIOR SERTIFIKAAT

GRADE 12/GRAAD 12

TECHNICAL MATHEMATICS P2/TEGNIESE WISKUNDE V2

NOVEMBER 2025

MARKING GUIDELINES/FINALE NASIENRIGLYNE

MARKS/PUNTE: 150

CODE/ KODE	EXPLANATION/VERDUIDELIKING
A	Accuracy/Akkuraatheid
AO	Answer only/Slegs antwoord
CA	Consistent accuracy/Volgehoue akkuraatheid
I	Identity/Identiteit
M	Method/Metode
NPR	No penalty for rounding/Geen penalisering vir afronding nie
NPU	No penalty for omitting units/Geen penalisering vir eenhede weggelaat nie
R	Rounding/Afronding
RE	Reason/Rede
S	Simplification/Vereenvoudiging
F	Formula/Formule
SF	Substitution in correct formula/Vervanging in korrekte formule
ST	Statement/Bewering
ST/RE	Statement with reason/Bewering met rede

These marking guidelines consist of 32 pages.  
*Hierdie nasienriglyne bestaan uit 32 bladsye.*

**NOTE:**

- If a candidate answers a question TWICE, only mark the FIRST attempt.
- The method of consistent accuracy marking must be applied in all aspects of the marking guidelines where applicable as indicated by the marking code CA.
- # Shows questions where a Tolerance Range will be applied:  
**Q 2.1.3 ; Q 3.3 ; Q 6.5 & Q 10.2.3**

**LET WEL:**

- Indien 'n kandidaat 'n vraag TWEE keer beantwoord, sien slegs die EERSTE poging na.
- Die metode van volgehoue akkuraatheid-nasien moet waar moontlik op alle aspekte van die nasienriglyne toegepas word, soos aangedui deur die nasien kode CA.
- # Toon vrae waar Toleransiewydte (Verdraagsaamheidsomvang) toegepas word:  
**V 2.1.3 ; V 3.3 ; V 6.5 & V 10.2.3**

**QUESTION/VRAAG 1**

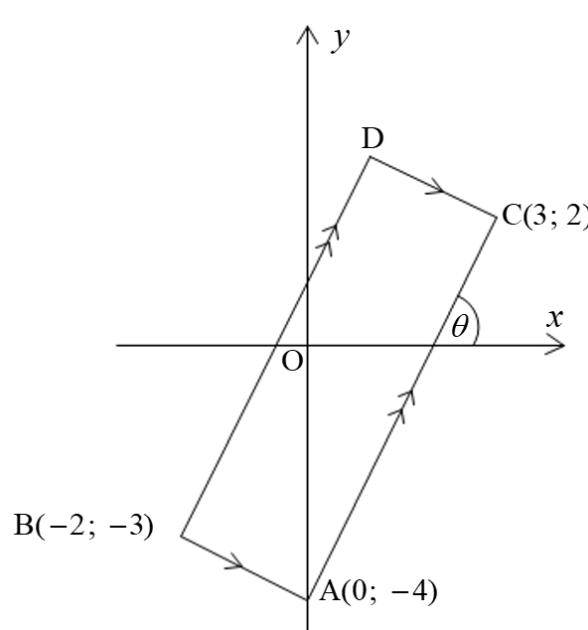
		
1.1	$OA = 4 \text{ units/eenhede}$	✓ length of /lengte van OA <span style="float: right;"><b>A</b> (1)</span>
1.2	$M = \left( \frac{x_A + x_B}{2}; \frac{y_A + y_B}{2} \right)$ $= \left( \frac{0 + (-2)}{2}; \frac{-4 + (-3)}{2} \right)$ $= \left( -1; -\frac{7}{2} \right) \text{ OR / OF } (-1; -3,5)$	✓ x - coordinate/koördinaat <span style="float: right;"><b>A</b></span> ✓ y - coordinate/koördinaat <span style="float: right;"><b>A</b></span> <span style="float: right;"><b>(2)</b></span>

<p>1.3</p>	$m_{AC} = \frac{y_A - y_C}{x_A - x_C}$ $= \frac{(-4) - (2)}{(0) - (3)} \text{ OR / OF } = \frac{(2) - (-4)}{(3) - (0)}$ $= 2$ <p style="text-align: center;"><b>OR / OF</b></p> $y - y_1 = m (x - x_1)$ $(-4) - (2) = m ((0) - (3))$ $-6 = m (-3)$ $m = \frac{-6}{-3} = 2$ <p style="text-align: center;"><b>OR / OF</b></p> $y = mx + c$ $y = mx - 4$ $2 = m(3) - 4$ $3m = 6$ $m = 2$	<p>✓ SF <span style="float: right;">A</span></p> <p>✓ value of/waarde van <math>m</math> <span style="float: right;">CA</span></p> <p style="text-align: center;"><b>OR / OF</b></p> <p>✓ SF <span style="float: right;">A</span></p> <p>✓ value of/waarde van <math>m</math> <span style="float: right;">CA</span></p> <p style="text-align: center;"><b>OR / OF</b></p> <p>✓ SF <span style="float: right;">A</span></p> <p>✓ value of/waarde van <math>m</math> <span style="float: right;">CA</span></p> <p><b>AO: Full marks/Volpunte</b> <span style="float: right;">CA</span></p> <p style="text-align: right;">(2)</p>
<p>1.4</p>	$\tan \theta = m_{AC}$ $\theta = \tan^{-1}(2)$ $\theta \approx 63,43^\circ$	<p>✓ SF <span style="float: right;">CA</span></p> <p>✓ value of/waarde van <math>\theta</math> <span style="float: right;">CA</span></p> <p><b>AO: Full marks/Volpunte</b> <span style="float: right;">CA</span></p> <p><b>NPR</b> <span style="float: right;">CA</span></p> <p style="text-align: right;">(2)</p>
<p>1.5</p>	<p>equal / gelyk <b>OR / OF</b> the same / dieselfde</p>	<p>✓ equal/gelyk <span style="float: right;">A</span></p> <p style="text-align: right;">(1)</p>
<p>1.6</p>	$y - (-3) = 2 (x - (-2))$ $y + 3 = 2x + 4$ <p style="text-align: center;"><b>OR / OF</b></p> $y = 2x + 1$	<p>✓ gradient/helling <span style="float: right;">CA</span></p> <p>✓ Subst./Vervang B <span style="float: right;">A</span></p> <p>✓ equation in form <math>y = \dots /</math>  <i>vergelyking in vorm <math>y = \dots</math></i> <span style="float: right;">CA</span></p> <p style="text-align: right;">(3)</p>

<p>1.7</p>	$\cos \alpha = -\frac{\sqrt{2}}{2}$ <p>ref. / verw. <math>\angle = 45^\circ</math>  <math>\therefore \alpha = 180^\circ - 45^\circ = 135^\circ</math>  <math>\therefore m = \tan(135^\circ) = -1</math></p> <p style="text-align: center;"><b>OR / OF</b></p> $\cos \alpha = -\frac{\sqrt{2}}{2}$ $x^2 + y^2 = r^2$ $(-\sqrt{2})^2 + y^2 = (2)^2$ $y^2 = 4 - 2$ $y^2 = \pm\sqrt{2}$ $\therefore y = \sqrt{2}$ $\tan \alpha = \frac{\sqrt{2}}{-\sqrt{2}}$ $\tan \alpha = -1$ $\therefore m = -1$	<p>✓ Ref. <math>\angle</math> / Verwys. <math>\angle</math>                    <b>A</b>                  ✓ value of/waarde van <math>\alpha</math>                    <b>CA</b>                  ✓ value of/waarde van <math>m</math>                    <b>A</b></p> <p style="text-align: center;"><b>OR / OF</b></p> <p>✓ Value of/Waarde van <math>y</math>                    <b>A</b>                  ✓ tan ratio/verhouding                    <b>CA</b>                  ✓ value of/waarde van <math>m</math>                    <b>CA</b>                  (3)</p>
		<b>[14]</b>

**QUESTION/VRAAG 2**

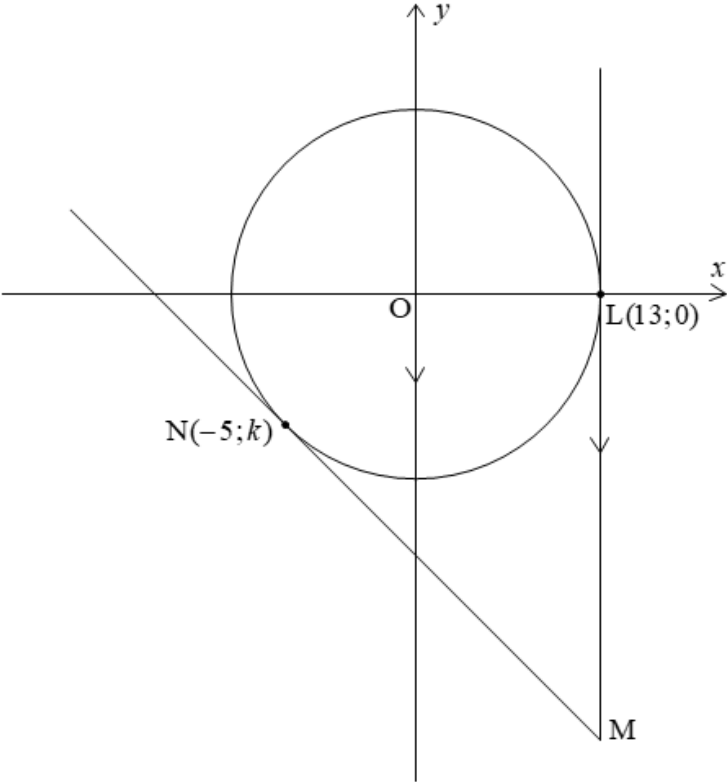
<p>2.1</p>			
<p>2.1.1</p>	$x^2 + y^2 = (13)^2$ <p style="text-align: right;"><b>OR / OF</b></p> $x^2 + y^2 = 169$ <p style="text-align: right;"><b>OR / OF</b></p> $x = \pm \sqrt{169 - y^2}$ <p style="text-align: right;"><b>OR / OF</b></p> $y = \pm \sqrt{169 - x^2}$ <p style="text-align: right;"><b>OR / OF</b></p> $(13)^2 + (0)^2 = r^2$ $169 = r^2$ $x^2 + y^2 = 169$	<p>✓✓ equation/vergeljking <b>A</b></p> <p style="text-align: right;"><b>OR / OF</b></p> <p>✓✓ equation/vergeljking <b>A</b></p> <p style="text-align: right;"><b>OR / OF</b></p> <p>✓✓ equation/vergeljking <b>A</b></p> <p style="text-align: right;"><b>OR / OF</b></p> <p>✓✓ equation/vergeljking <b>A</b></p> <p style="text-align: right;"><b>OR / OF</b></p> <p>✓ substitution/vervangings <b>A</b></p> <p>✓ equation/vergeljking <b>A</b></p> <p><b>AO: Full marks/Volpunte</b></p> <p style="text-align: right;">(2)</p>	
<p>2.1.2</p>	$(-5)^2 + (k)^2 = 169$ $\therefore k^2 = 144$ $\therefore k = -12$	<p>✓ substitution/vervangings <b>CA</b></p> <p>✓ value of/waarde van k <b>CA</b></p> <p><b>AO: Full marks/Volpunte</b></p> <p style="text-align: right;">(2)</p>	

<p>2.1.3 #</p>	<p>Since / Omdat M(13 ; y)</p> $m_{ON} = \frac{12}{5}$ $m_{MN} = -\frac{5}{12}$ <p><math>y - (-12) = -\frac{5}{12}(x - (-5))</math> <b>OR / OF</b> <math>-12 = -\frac{5}{12}(-5) + c</math></p> $y = -\frac{5}{12}x - \frac{25}{12} - 12 \qquad c = -\frac{25}{12} - 12 = -\frac{169}{12}$ $\therefore y = -\frac{5}{12}x - \frac{169}{12}$ $\therefore y = -\frac{5}{12}(13) - \frac{169}{12}$ $\therefore y = -\frac{39}{2} = -19,5$ <p><math>\therefore M(13; -19,5)</math></p> <p style="text-align: center;"><b>OR / OF</b></p> <p>Since / Omdat M(13 ; y)</p> $x \cdot x_1 + y \cdot y_1 = r^2$ $-5x - 12y = 169$ $-12y = 5x + 169$ $\therefore y = -\frac{5}{12}x - \frac{169}{12}$ $\therefore y = -\frac{5}{12}(13) - \frac{169}{12}$ $\therefore y = -\frac{39}{2} = -19,5$ <p><math>\therefore M(13; -19,5)</math></p> <p style="text-align: center;"><b>OR / OF</b></p> <p>Since / Omdat M(13 ; y)</p> <p>and/en <math>d_{LM} = d_{NM}</math> <math>\left( \begin{array}{l} \text{tangents from same pt. /} \\ \text{Raaklyne vanuit dies pt} \end{array} \right)</math></p> $\sqrt{(13 - (-5))^2 + (y - (-12))^2} = y$ $(13 - (-5))^2 + (y - (-12))^2 = y^2$ $324 + y^2 + 24y + 144 = y^2$ $24y = -468$ $y = -\frac{39}{2} = -19,5$ <p>M(13; -19,5)</p>	<p>✓ value of/waarde van x <b>A</b></p> <p>✓ gradient/gradjënt of/van ON <b>CA</b></p> <p>✓ gradient/gradjënt of/van MN <b>CA</b></p> <p>✓ equation/vergelyking <b>CA</b></p> <p>✓ value of/waarde van y <b>CA</b></p> <p style="text-align: center;"><b>OR / OF</b></p> <p>✓ value of/waarde van x <b>A</b></p> <p>✓ <b>F</b> <b>A</b></p> <p>✓ subst/vervang <b>CA</b></p> <p>✓ equation/vergelyking <b>CA</b></p> <p>✓ value of/waarde van y <b>CA</b></p> <p style="text-align: center;"><b>OR / OF</b></p> <p>✓ value of/waarde van x <b>A</b></p> <p>✓ statement/bewering <b>A</b></p> <p>✓ subst/vervang <b>CA</b></p> <p>✓ squaring both sides / kwadreer beide kante <b>CA</b></p> <p>✓ value of/waarde van y <b>CA</b></p> <p style="text-align: right;">(5)</p>
--------------------	--	--

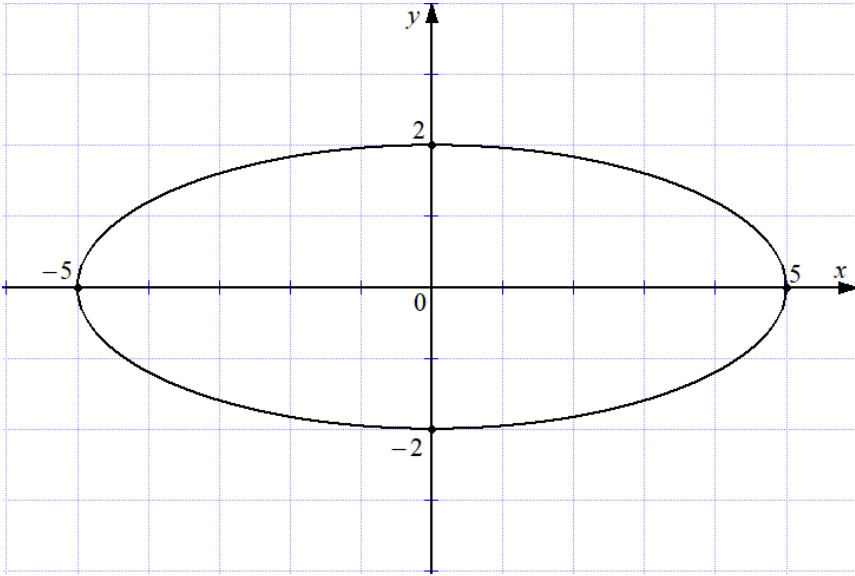
2.2		<p>✓ x-intercept/afsnit <b>A</b> ✓ y-intercept/afsnit <b>A</b> ✓ elliptical shape/ elliptiese vorm <b>A</b></p> <p>(3) <b>ACCEPT/AANVAAR:</b> <math>\sqrt{25}</math> and / en <math>-\sqrt{25}</math> <math>\sqrt{4}</math> and / en <math>-\sqrt{4}</math></p>
		<b>[12]</b>

**QUESTION/VRAAG 3**

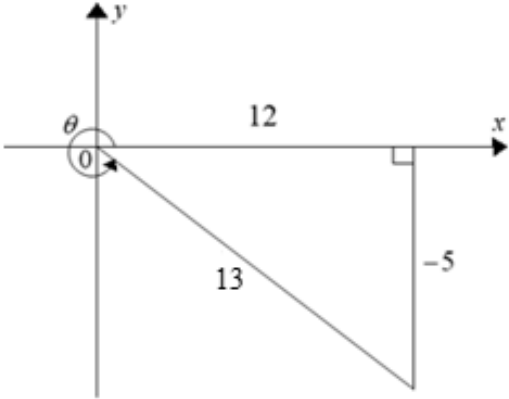
<p>3.1</p>	$\sqrt{\sin B + \sec A}$ $= \sqrt{\sin 30,5^\circ + \sec 72^\circ}$ $= \sqrt{\sin 30,5^\circ + \frac{1}{\cos 72^\circ}}$ $\approx 1,93$	<p>✓ substitution/<i>vervanging</i>      <b>A</b></p> <p>✓ <b>I</b>      <b>A</b></p> <p>✓ <b>S</b>      <b>CA</b></p> <p><b>NPR</b></p> <p><b>AO: Full marks/Volpunte</b></p> <p>(3)</p>
<p>3.2.1</p>	 <p> <math>\sin \theta = -\frac{5}{13}</math>  <math>x^2 + (-5)^2 = (13)^2</math>  <math>x = 12</math>  <math>\cos \theta = \frac{12}{13}</math> </p> <p style="text-align: center;"><b>OR / OF</b></p> <p> <math>\cos \theta = \sqrt{1 - \sin^2 \theta}</math>  <math>= \sqrt{1 - \left(\frac{-5}{13}\right)^2}</math>  <math>= \frac{12}{13}</math> </p>	<p>✓ Pyth. Theorem/<i>Stelling</i>      <b>A</b></p> <p>✓ value of/<i>waarde van x</i>      <b>CA</b></p> <p>✓ ratio/<i>verhouding</i>      <b>CA</b></p> <p style="text-align: center;"><b>OR / OF</b></p> <p>✓ <b>I</b>      <b>A</b></p> <p>✓ ratio of/<i>verhouding van sin</i></p> <p>✓ ratio/<i>verhouding</i>      <b>A</b></p> <p>   <b>CA</b></p> <p>(3)</p>
<p>3.2.2</p>	<p> <math>\cot \theta - \operatorname{cosec} \theta</math>  <math>= \left(-\frac{12}{5}\right) - \left(-\frac{13}{5}\right)</math>  <math>= \frac{1}{5}</math> </p>	<p>✓ cot ratio/<i>verhouding</i>      <b>CA</b></p> <p>✓ cosec ratio/<i>verhouding</i>      <b>A</b></p> <p>✓ <b>S</b>      <b>CA</b></p> <p><b>ACCEPT/AANVAAR:</b>          Correct decimal values./  <i>Korrekte desimale waardes.</i></p> <p>(3)</p>

<p>3.3 #</p>	<p><math>\cot x = -0,587</math>  <math>\tan x = -\frac{1}{0,587}</math> <b>OR / OF</b> <math>\tan x = -1,704</math>                  Ref. <math>\angle \approx 59,59^\circ</math>  <math>x \approx 180^\circ - 59,59^\circ</math> or/of <math>x \approx 360^\circ - 59,59^\circ</math>  <math>x \approx 120,41^\circ</math> or/of <math>x \approx 300,41^\circ</math></p>	<p>✓ tan ratio/verhouding      <b>A</b>                  ✓ ref. angle/verw. hoek      <b>CA</b>                  ✓ value of/waarde van <math>x</math>      <b>CA</b>                  ✓ value of waarde van <math>x</math>      <b>CA</b>                  (4)</p>
		<p><b>[13]</b></p>

**QUESTION/VRAAG 4**

4.1.1	$\tan x$	✓ reduction/ <i>reduksie</i> <b>A</b> (1)
4.1.2	$\frac{\cos x}{\sin x}$	✓ <b>I</b> <b>A</b> (1)
4.1.3	$\{ 0^\circ ; 90^\circ ; 180^\circ ; 270^\circ ; 360^\circ \}$	✓✓ any two values/ <i>enige twee</i> <i>waardes</i> <b>A</b> (2)
4.1.4	$\frac{\sin(180^\circ + x) \cdot \sin(360^\circ - x) + \cos(2\pi - x) \cdot \cos x}{\sin x} + \frac{1}{\tan(180^\circ + x)}$ $= \frac{-\sin x \cdot -\sin x + \cos x \cdot \cos x}{\sin x} + \frac{1}{\tan x}$ $= \frac{\sin^2 x + \cos^2 x}{\sin x} + \frac{\cos x}{\sin x}$ $= \frac{1}{\sin x} + \frac{\cos x}{\sin x}$ $= \frac{1 + \cos x}{\sin x} \text{ OR / OF } = \operatorname{cosec} x + \cot x$	✓ $-\sin x$ <b>A</b> ✓ $-\sin x$ <b>A</b> ✓ $\cos x$ <b>A</b>  ✓ <b>I (1)</b> <b>A</b> ✓ <b>S</b> <b>CA</b> (5)
4.2.1	$\sin \theta(1 - \cos \theta)$	✓ factors/ <i>faktore</i> <b>A</b> (1)

<p>4.2.2</p>	$\text{LHS} = \frac{\sin \theta - \cos \theta \cdot \sin \theta}{\cos \theta - (1 - \sin^2 \theta)}$ $= \frac{\sin \theta(1 - \cos \theta)}{\cos \theta - \cos^2 \theta}$ $= \frac{\sin \theta(1 - \cos \theta)}{\cos \theta(1 - \cos \theta)}$ $= \frac{\sin \theta}{\cos \theta}$ $= \tan \theta = \text{RHS}$ <p style="text-align: center;"><b>OR / OF</b></p> $\text{LHS} = \frac{\sin \theta - \cos \theta \cdot \sin \theta}{\cos \theta - (1 - \sin^2 \theta)}$ $= \frac{\sin \theta - \cos \theta \cdot \sin \theta}{\cos \theta - 1 + \sin^2 \theta}$ $= \frac{\sin \theta(1 - \cos \theta)}{\cos \theta - 1 + 1 - \cos^2 \theta}$ $= \frac{\sin \theta(1 - \cos \theta)}{\cos \theta(1 - \cos \theta)}$ $= \frac{\sin \theta}{\cos \theta}$ $= \tan \theta = \text{RHS}$	<p>✓ <b>I</b> (<math>\cos^2 \theta</math>)      <b>A</b></p> <p>✓ common fact/ <i>gemeensk. fakt</i>      <b>A</b></p> <p>✓ <b>S</b>      <b>A</b></p> <p style="text-align: center;"><b>OR / OF</b></p> <p>✓ <b>I</b> (<math>1 - \cos^2 \theta</math>)      <b>A</b></p> <p>✓ common fact/ <i>gemeensk. fakt</i>      <b>A</b></p> <p>✓ <b>S</b>      <b>A</b></p> <p style="text-align: right;">(3)</p>
		<p><b>[13]</b></p>

**QUESTION/VRAAG 5**

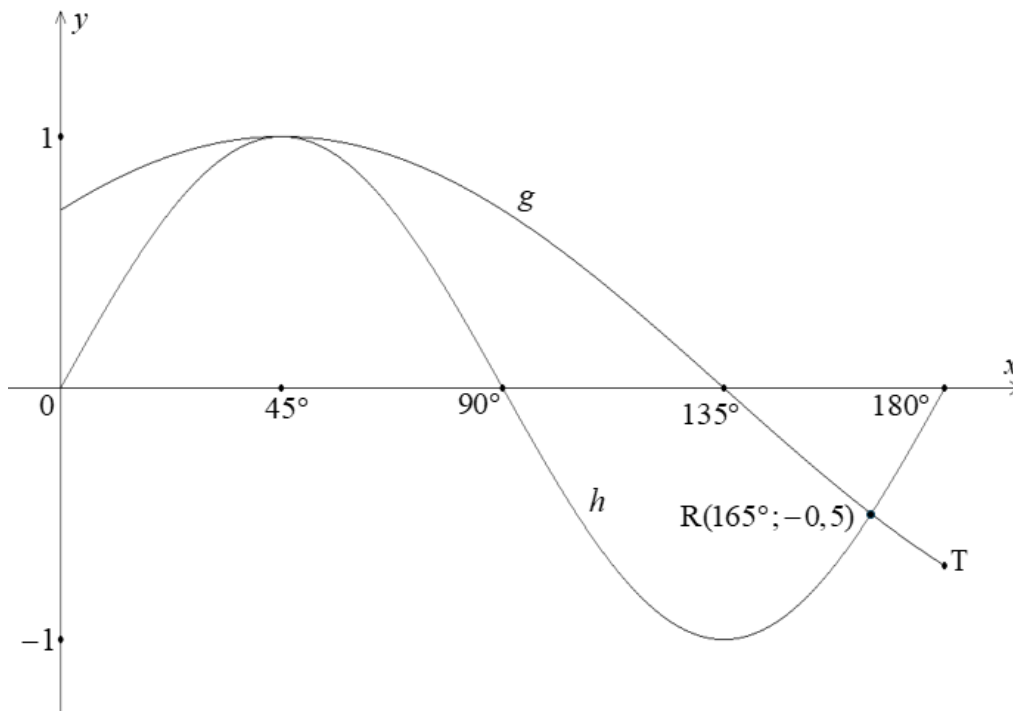

5.1	$m = 2$ and / en $p = 45^\circ$	✓ value of/waarde van $p$ <b>A</b> ✓ value of/waarde van $m$ <b>A</b> (2)
5.2	$180^\circ$	✓ period/periode <b>A</b> (1)
5.3	1	✓ value/waarde <b>A</b> (1)
5.4.1	$165^\circ < x \leq 180^\circ$  <p style="text-align: center;"><b>OR / OF</b></p> $x \in ( 165^\circ ; 180^\circ ]$  <p style="text-align: center;"><b>OR / OF</b></p> $x > 165^\circ$ and / en $x \leq 180^\circ$  <p style="text-align: center;"><b>OR / OF</b></p> Greater than $165^\circ$ and smaller or equal to $180^\circ$ . / Groter as $165^\circ$ en kleiner of gelyk aan $180^\circ$ .	✓ endpoints/eindpunte <b>A</b> ✓ notation/notasie <b>A</b> <p style="text-align: center;"><b>OR / OF</b></p> ✓ endpoints/eindpunte <b>A</b> ✓ notation/notasie <b>A</b> <p style="text-align: center;"><b>OR / OF</b></p> ✓ endpoints/eindpunte <b>A</b> ✓ notation/notasie <b>A</b> <p style="text-align: center;"><b>OR / OF</b></p> ✓ endpoints/eindpunte <b>A</b> ✓ Correct interval/Korrekte interval <b>A</b> (2)

<p>5.4.2</p>	<p><math>0^\circ \leq x \leq 90^\circ</math></p> <p><math>135^\circ \leq x \leq 180^\circ</math></p> <p style="text-align: center;"><b>OR / OF</b></p> <p><math>x \in [ 0^\circ ; 90^\circ ]</math></p> <p style="text-align: center;">or / of</p> <p><math>x \in [135^\circ; 180^\circ]</math></p> <p style="text-align: center;"><b>OR / OF</b></p> <p><math>x \geq 0^\circ</math> and / en <math>x \leq 90^\circ</math></p> <p style="text-align: center;">or / of</p> <p><math>x \geq 135^\circ</math> and / en <math>x \leq 180^\circ</math></p> <p style="text-align: center;"><b>OR / OF</b></p> <p>From <math>0^\circ</math> to <math>90^\circ</math> / Vanaf <math>0^\circ</math> tot by <math>90^\circ</math></p> <p style="text-align: center;">or / of</p> <p>From <math>135^\circ</math> to <math>180^\circ</math> / Vanaf <math>135^\circ</math> tot by <math>180^\circ</math></p>	<p>✓ critical values/ <i>kritiese waardes</i>      <b>A</b></p> <p>✓ notation/ <i>notasie</i>      <b>A</b></p> <p>✓ critical values/ <i>kritiese waardes</i>      <b>A</b></p> <p>✓ notation/ <i>notasie</i>      <b>A</b></p> <p style="text-align: center;"><b>OR / OF</b></p> <p>✓ critical values/ <i>kritiese waardes</i>      <b>A</b></p> <p>✓ notation/ <i>notasie</i>      <b>A</b></p> <p>✓ critical values/ <i>kritiese waardes</i>      <b>A</b></p> <p>✓ notation/ <i>notasie</i>      <b>A</b></p> <p style="text-align: center;"><b>OR / OF</b></p> <p>✓ critical values/ <i>kritiese waardes</i>      <b>A</b></p> <p>✓ notation/ <i>notasie</i>      <b>A</b></p> <p>✓ critical values/ <i>kritiese waardes</i>      <b>A</b></p> <p>✓ notation/ <i>notasie</i>      <b>A</b></p> <p style="text-align: center;"><b>OR / OF</b></p> <p>✓ endpoints/ <i>eindpunte</i>      <b>A</b></p> <p>✓ Correct interval/ <i>Regte interval</i>      <b>A</b></p> <p>✓ endpoints/ <i>eindpunte</i>      <b>A</b></p> <p>✓ Correct interval/ <i>Regte interval</i>      <b>A</b></p> <p style="text-align: right;">(4)</p>
<p>5.5</p>	<p><math>h(x) = \sin 2x - 1</math></p> <p style="text-align: center;"><b>OR / OF</b></p> <p><math>h(x) = \sin mx - 1</math></p>	<p>✓ <math>\sin 2x - 1</math>      <b>CA</b></p> <p style="text-align: center;"><b>OR / OF</b></p> <p>✓ <math>\sin mx - 1</math>      <b>A</b></p> <p style="text-align: right;">(1)</p>
		<p style="text-align: right;"><b>[11]</b></p>

**QUESTION/VRAAG 6**

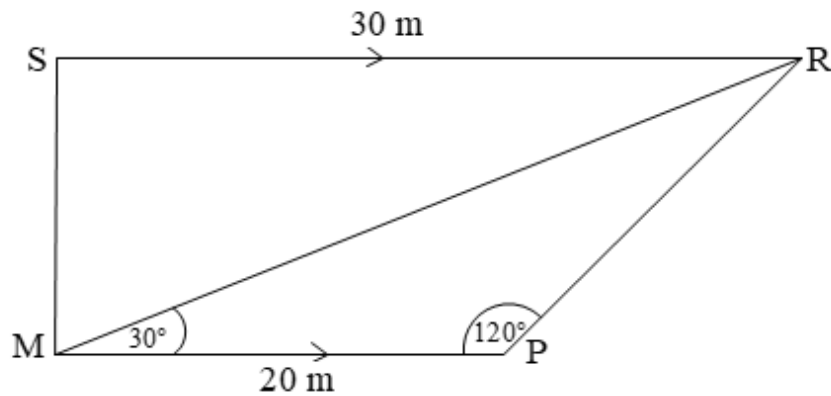

**NOTE:**

If an angle of 90° is assumed – **BREAKDOWN**, hence no marks may be awarded.

**NOTA:**

Indien ‘n hoek van 90° aangeneem word = **AFBREEK**, vervolgens mag geen punte toegeken word nie.

6.1	$\hat{M R P} = 180^\circ - 120^\circ - 30^\circ$ $= 30^\circ$	✓ size of/grootte van $\hat{M R P}$ <b>A</b> (1)
6.2	Isosceles triangle/Gelykbenige driehoek <b>OR / OF</b> Obtuse angled triangle/Stomphoekige driehoek	✓ isosceles/gelykbenig <b>A</b> <b>OR / OF</b> ✓ obtuse angled/Stomphoekig <b>A</b> (1)
6.3	$\frac{MR}{\sin P} = \frac{MP}{\sin \hat{M R P}}$ $\frac{MR}{\sin 120^\circ} = \frac{20}{\sin 30^\circ}$ $MR = \frac{20 \sin 120^\circ}{\sin 30^\circ}$ $MR = 20\sqrt{3} \text{ units} \approx 34,64 \text{ units}$ <p style="text-align: center;"><b>OR / OF</b></p> $MP = PR = 20 \text{ m}$ $MR = \sqrt{(20)^2 + (20)^2 - 2(20)(20)\cos 120^\circ}$ $= 20\sqrt{3} \text{ units} \approx 34,64 \text{ units}$	✓ sine rule/sinusreël <b>A</b> ✓ Subst. / Vervang. <b>CA</b> ✓ length of/lengte van MR <b>CA</b> <b>OR / OF</b> ✓ length / lengte PR <b>A</b> ✓ Subst. into / Vervang. in cosine rule/cosinusreël <b>CA</b> ✓ length /lengte MR <b>CA</b> (3)

<p>6.4</p>	<p><math>\hat{MRS} = 30^\circ</math> (alt. <math>\angle</math>s/verw. <math>\angle</math>e; <math>SR \parallel MP</math>)</p>	<p>✓ <b>ST</b> <b>A</b>                  ✓ <b>RE</b> <b>A</b>                  (2)</p>
<p>6.5 #</p>	<p><math>SM^2 = SR^2 + MR^2 - 2SR \cdot MR \cos \hat{MRS}</math>  <math>SM^2 = (30)^2 + (20\sqrt{3})^2 - 2(30)(20\sqrt{3}) \cos 30^\circ</math>  <math>= 300</math>  <math>SM = 10\sqrt{3} \approx 17,32</math>  <math>SM^2 + SR^2 = (10\sqrt{3})^2 + (30)^2</math>  <math>= 1200</math>  <math>MR^2 = (20\sqrt{3})^2</math>  <math>= 1200</math>  <math>\therefore SM^2 + SR^2 = MR^2</math>  <math>\therefore \Delta MRS</math> is a right-angled triangle  <math>\therefore \Delta MRS</math> is 'n reghoekige driehoek</p> <p style="text-align: center;"><b>OR / OF</b></p> <p><math>SM^2 = SR^2 + MR^2 - 2SR \cdot MR \cos \hat{MRS}</math>  <math>SM^2 = (30)^2 + (20\sqrt{3})^2 - 2(30)(20\sqrt{3}) \cos 30^\circ</math>  <math>= 300</math>  <math>SM = 10\sqrt{3} \approx 17,32</math>  <math>\cos \hat{S} = \frac{(10\sqrt{3})^2 + (30)^2 - (20\sqrt{3})^2}{2(10\sqrt{3})(30)}</math>  <math>\hat{S} = \cos^{-1}\left(\frac{0}{600\sqrt{3}}\right)</math>  <math>\hat{S} = 90^\circ</math>  <math>\therefore \Delta MRS</math> is a right-angled triangle  <math>\therefore \Delta MRS</math> is 'n reghoekige driehoek</p> <p style="text-align: center;"><b>OR / OF</b></p>	<p>✓ <b>SF</b> cosine rule/  <i>cosinusreël</i> <b>CA</b>                  ✓ length of/<i>lengte van</i>                  SM <b>CA</b>                  ✓ value of/<i>waarde van</i>  <math>SM^2 + SR^2</math> <b>CA</b>                  ✓ value of/ <i>waarde van</i>  <math>MR^2</math> <b>CA</b>                  ✓ <math>SM^2 + SR^2 = MR^2</math> <b>CA</b></p> <p style="text-align: center;"><b>OR / OF</b></p> <p>✓ <b>SF</b> cosine rule/  <i>cosinusreël</i> <b>CA</b>                  ✓ length of/<i>lengte van</i>                  SM <b>CA</b>                  ✓ <b>SF</b> cosine rule/  <i>cosinusreël</i> <b>CA</b>                  ✓ <math>\cos^{-1}\left(\frac{0}{600\sqrt{3}}\right)</math> <b>CA</b>                  ✓ Size of/  <i>grootte van</i> <math>\hat{S}</math> <b>CA</b></p> <p style="text-align: center;"><b>OR / OF</b></p>

<p> <math>SM^2 = SR^2 + MR^2 - 2SR \cdot MR \cos \hat{MRS}</math>  <math>SM^2 = (30)^2 + (20\sqrt{3})^2 - 2(30)(20\sqrt{3})\cos 30^\circ</math>  <math>= 300</math>  <math>SM = 10\sqrt{3} \approx 17,32</math> </p> <p> <math>\frac{\sin \hat{S}}{s} = \frac{\sin \hat{R}}{r}</math>  <math>\frac{\sin \hat{S}}{20\sqrt{3}} = \frac{\sin 30^\circ}{10\sqrt{3}}</math>  <math>\sin \hat{S} = 1</math>  <math>\hat{S} = \sin^{-1}(1)</math>  <math>\hat{S} = 90^\circ</math> </p> <p> <math>\therefore \Delta MRS</math> is a right-angled triangle  <math>\therefore \Delta MRS</math> is 'n reghoekige driehoek         </p> <p style="text-align: center;"><b>OR / OF</b></p> <p> <math>\sin 30^\circ = \frac{h}{20\sqrt{3}}</math>  <math>h = 20\sqrt{3} \cdot \sin 30^\circ</math>  <math>h = 10\sqrt{3} \approx 17,32</math> </p> <hr/> <p> <math>SM = \sqrt{(30)^2 + (20\sqrt{3})^2 - 2(30)(20\sqrt{3}) \cdot \cos 30^\circ}</math>  <math>SM = 10\sqrt{3} \approx 17,32</math> </p> <p> <math>\therefore SM =</math> Perp. height/<i>loodregte hoogte</i>              Therefore <math>SMR</math> is a right-angled triangle. /  <i>Daarom is <math>SMR</math> 'n reghoekige driehoek.</i> </p>	<p>                 ✓ <b>SF</b> cosine rule/  <i>cosinusreël</i> <b>CA</b> </p> <p>                 ✓ length of/<i>lengte van</i>                  SM <b>CA</b> </p> <p>                 ✓ <b>SF</b> sine rule/<i>sinusreël</i>  <b>CA</b> </p> <p>                 ✓ <math>\sin^{-1}(1)</math> <b>CA</b> </p> <p>                 ✓ Size of/<i>grootte</i>                  van <math>\hat{S}</math> <b>CA</b> </p> <p style="text-align: center;"><b>OR / OF</b></p> <p>                 ✓ sine ratio/<i>verh.</i> <b>CA</b> </p> <p>                 ✓ <math>h</math> <b>CA</b> </p> <p>                 ✓ <b>SF</b> cosine rule/  <i>cosinusreël</i> <b>CA</b> </p> <p>                 ✓ length of/<i>lengte van</i>                  SM <b>CA</b> </p> <p>                 ✓ Conclusion/  <i>Gevolgtrekking</i> <b>CA</b>                  (5)             </p>
	<p><b>[12]</b></p>

**QUESTION/VRAAG 7**

7.1

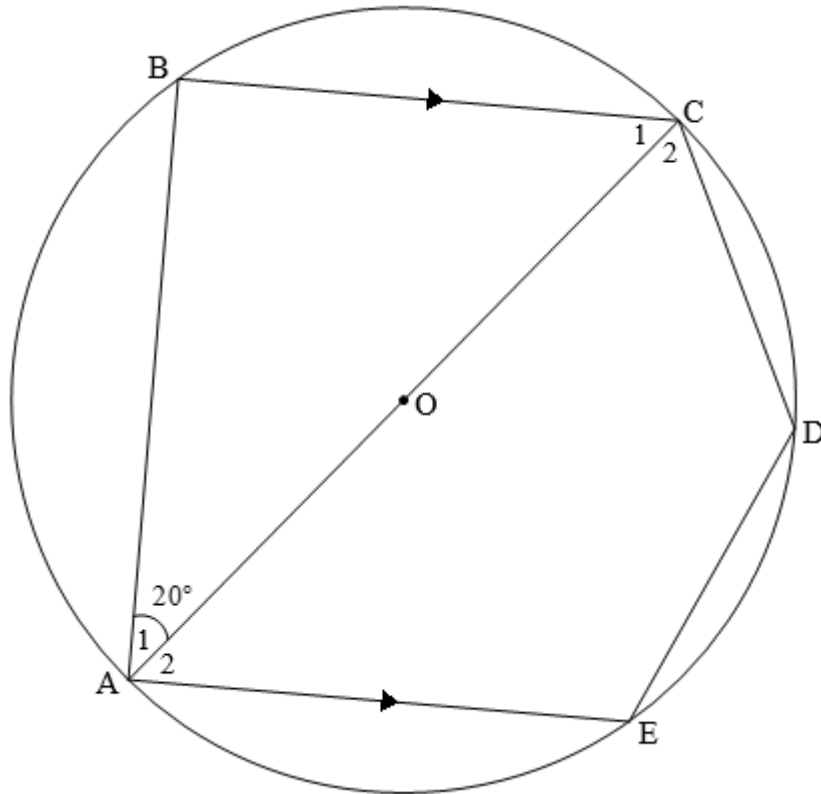

<p>7.1.1</p>	<p>The angle subtended by the diameter at the circumference of the circle is <math>90^\circ</math>. (<math>\angle</math> in semi-circle) /  <i>Die omtrekshoek wat deur die middellyn onderspan word, is <math>90^\circ</math>. (<math>\angle</math> in halwe sirkel)</i></p> <p style="text-align: center;"><b>OR / OF</b></p> <p>Diameter subtends right angle. / <i>Diameter onderspan regtehoek.</i></p>	<p>✓ <b>RE</b>      <b>A</b></p> <p style="text-align: center;"><b>OR / OF</b></p> <p>✓ <b>RE</b>      <b>A</b> (1)</p>
<p>7.1.2</p>	<p><math>\hat{A}_2 = 70^\circ</math> (co-int <math>\angle</math>s / ko-binne <math>\angle</math>e; <math>BC \parallel AE</math>)</p> <p><math>\therefore \hat{D} = 110^\circ</math> (opp <math>\angle</math>s of cyclic quad / teenoorst <math>\angle</math>e van kdvk)</p> <p style="text-align: center;"><b>OR / OF</b></p> <p><math>\hat{C}_1 = 70^\circ</math> (Int. <math>\angle</math>s <math>\Delta</math> / Binne <math>\angle</math>e <math>\Delta</math>; <math>BC \parallel AE</math>)</p> <p><math>\hat{A}_2 = 70^\circ</math> (alt. <math>\angle</math>s / verw. <math>\angle</math>e; <math>BC \parallel AE</math>)</p> <p><math>\therefore \hat{D} = 110^\circ</math> (opp <math>\angle</math>s of cyclic quad / teenoorst <math>\angle</math>e van kdvk)</p>	<p>✓ <b>ST</b>      <b>A</b></p> <p>✓ <b>ST</b>      <b>CA</b></p> <p>✓ <b>RE</b>      <b>A</b></p> <p style="text-align: center;"><b>OR / OF</b></p> <p>✓ <b>ST</b>      <b>A</b></p> <p>✓ <b>ST</b>      <b>CA</b></p> <p>✓ <b>RE</b>      <b>A</b> (3)</p>

7.2

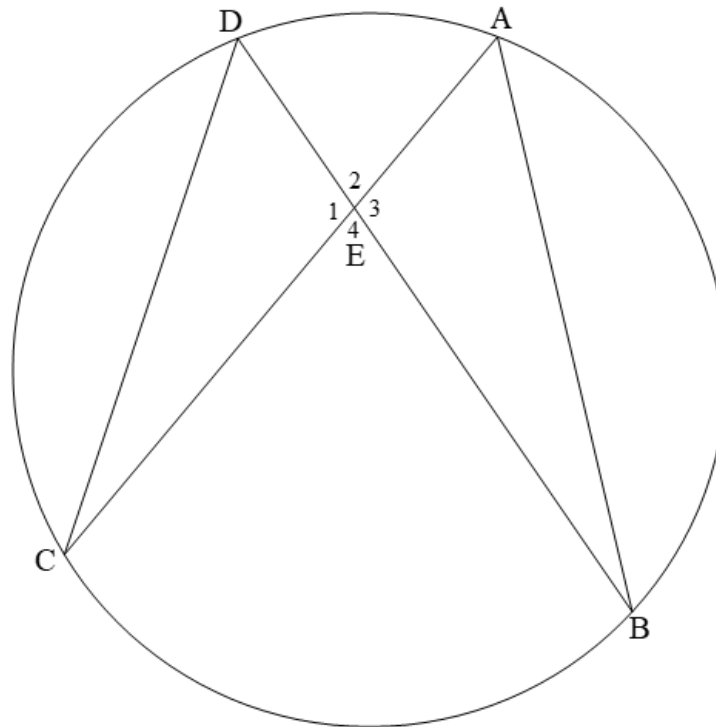

7.2.1	equal./gelyk. <b>OR / OF</b> the same./dieselfde.	✓ <b>ST</b>	<b>A</b> (1)
7.2.2 (a)	∠s in the same segment/ ∠e in dieselfde segment <b>OR / OF</b> ∠s subt. by same arc/chord./ ∠e onderspan deur dieselfde boog/koord.	✓ <b>RE</b> <b>OR / OF</b> ✓ <b>RE</b>	<b>A</b> <b>A</b> <b>A</b> (1)
7.2.2 (b)	Vertical opposite ∠s / regoorstaande ∠e	✓ <b>ST</b>	<b>A</b> (1)
7.2.2 (c)	∠, ∠, ∠ <b>OR / OF</b> A, A, A / H, H, H <b>OR / OF</b> Equiangular triangles/Gelykhoekige driehoeke	✓ <b>RE</b> <b>OR / OF</b> ✓ <b>RE</b>	<b>A</b> <b>A</b> <b>A</b> (1)
			<b>[8]</b>

**QUESTION/VRAAG 8**

8.1

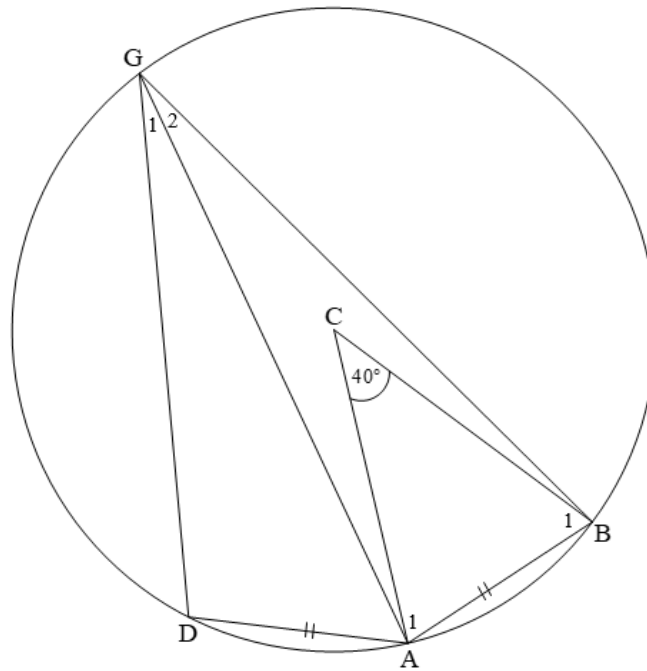

8.1.1	$\hat{G}_1 = \hat{G}_2$	✓ <b>ST</b>	<b>A</b> (1)
8.1.2	$\hat{G}_2 = 20^\circ$ $\left( \begin{array}{l} \angle \text{ at centre} = 2 \times \angle \text{ at circ. /} \\ \text{Mdpt. } \angle = 2 \times \text{omtreks } \angle \end{array} \right)$	✓ <b>ST</b> ✓ <b>RE</b>	<b>A</b> <b>A</b> (2)
8.1.3	$\angle$ s opp = sides / $\angle$ e teenoor gelyke sye	✓ <b>RE</b>	<b>A</b> (1)
8.1.4	$\hat{A}_1 + \hat{B}_1 + \hat{A}CB = 180^\circ$ (Int. $\angle$ s $\Delta$ / Binne $\angle$ e $\Delta$ ) $\hat{A}_1 = \frac{180^\circ - 40^\circ}{2}$ $\hat{A}_1 = 70^\circ$ ( $\angle$ s opp. = sides / $\angle$ e teenoor = sye)	✓ <b>RE</b>  ✓ $70^\circ$	<b>A</b>  <b>A</b> (2)
8.1.5	$\hat{D}AC + 70^\circ + 40^\circ = 180^\circ$ (opp. $\angle$ s cyclic quad / teenoorst. $\angle$ e kdvh) $\therefore \hat{D}AC = 70^\circ$	✓ <b>ST</b> ✓ <b>RE</b>  ✓ <b>ST</b>	<b>CA</b> <b>A</b>  <b>CA</b> (3)
8.2.1	exterior / buite	✓ <b>ST</b> <b>ACCEPT/AANVAAR:</b> outside/buitekant	<b>A</b>   (1)
8.2.2	interior / binne	✓ <b>ST</b> <b>ACCEPT/AANVAAR:</b> inside/binnekant	<b>A</b>   (1)

8.3

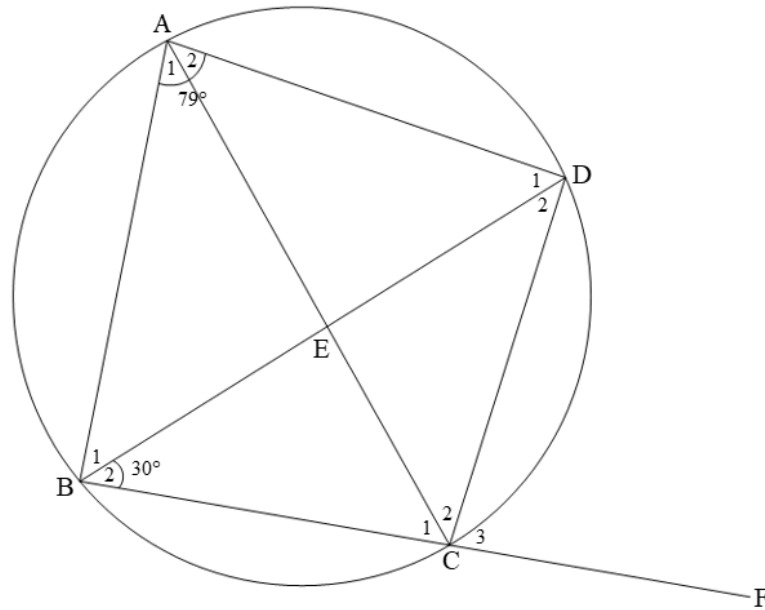

8.3.1(a)	$\hat{C}_3 = 79^\circ$ (Ext. $\angle$ cyclic. quad / <i>Buite <math>\angle</math> kdvh.</i> )	✓ <b>ST</b> ✓ <b>RE</b>	<b>A</b> <b>A</b> (2)
8.3.1(b)	$\hat{D}_2 = 49^\circ$ (Ext. $\angle \Delta$ / <i>Buite <math>\angle \Delta</math></i> ) <p style="text-align: center;"><b>OR / OF</b></p> $\hat{BCD} = 101^\circ$ ( $\angle$ s on str. line / <i><math>\angle</math>e opreguitlyn</i> ) $\hat{D}_2 = 49^\circ$ (Int. $\angle$ s $\Delta$ / <i>Binne <math>\angle</math>e <math>\Delta</math></i> ) <p style="text-align: center;"><b>OR / OF</b></p> $\hat{B}_2 = \hat{A}_2 = 30^\circ$ ( $\angle$ s in same segm./ <i><math>\angle</math>e in dies. segm.</i> ) $\therefore \hat{A}_1 = 49^\circ$ $\hat{A}_1 = \hat{D}_2 = 49^\circ$ ( $\angle$ s in same segm./ <i><math>\angle</math>e in dies. segm.</i> )	✓ <b>ST</b> ✓ <b>RE</b>  ✓ <b>ST</b> ✓ <b>ST</b>  ✓ <b>ST</b>	<b>CA</b> <b>A</b>  <b>CA</b> <b>CA</b>  <b>CA</b> (2)
8.3.1(c)	$\hat{D}_1 = 180^\circ - 79^\circ - 49^\circ$ (Co - int. $\angle$ s suppl. ; $AB \parallel CD$ ) $\hat{D}_1 = 52^\circ$ ( <i>Ko - Binne <math>\angle</math>e sup pl. ; <math>AB \parallel CD</math></i> ) <p style="text-align: center;"><b>OR / OF</b></p> $\hat{B}_1 = 49^\circ$ (alt. $\angle$ 's =; <i>verw. <math>\angle</math>'e = ; <math>AB \parallel CD</math></i> ) $\therefore \hat{D}_1 = 52^\circ$ (Int. $\angle$ 's $\Delta$ / <i>Binne <math>\angle</math>'e <math>\Delta</math></i> )	✓ <b>ST</b> ✓ <b>RE</b> ✓ <b>ST</b>  ✓ <b>ST</b> ✓ <b>RE</b> ✓ <b>ST</b>	<b>CA</b> <b>A</b> <b>CA</b>  <b>CA</b> <b>A</b> <b>CA</b> (3)

<p>8.3.2</p>	<p> <math>\hat{C}_1 = \hat{D}_1 = 52^\circ</math>    <math>\left( \begin{array}{l} \angle s \text{ in same segment /} \\ \angle e \text{ in dies. segment} \end{array} \right)</math>  <math>\hat{C}_2 = 49^\circ</math>    <math>\left( \begin{array}{l} \angle s \text{ on str. line /} \\ \angle e \text{ op reguitlyn} \end{array} \right)</math>  <math>\hat{D}_2 = \hat{C}_2 = 49^\circ</math>    <math>\left( \begin{array}{l} \text{sides opp.} = \angle s / \\ \text{sye teenoor} = \angle e \end{array} \right)</math>                      CE = DE  <p style="text-align: center;"><b>OR / OF</b></p> <math>\hat{C}_2 = \hat{B}_1 = 49^\circ</math>    <math>\left( \begin{array}{l} \angle s \text{ in same segment /} \\ \angle e \text{ in dies. segment} \end{array} \right)</math>  <math>\hat{D}_2 = \hat{C}_2 = 49^\circ</math>    <math>\left( \begin{array}{l} \text{sides opp.} = \angle s / \\ \text{sye teenoor} = \angle e \end{array} \right)</math>                      CE = DE                 </p>	<p>                     ✓ <b>ST</b>            <b>CA</b>                      ✓ <b>RE</b>            <b>A</b>                        ✓ <b>ST</b>            <b>CA</b>                      ✓ <b>RE</b>            <b>A</b>                        ✓ <b>ST</b>            <b>CA</b>                      ✓ <b>RE</b>            <b>A</b>                      (4)                 </p>
		<p>[22]</p>

**QUESTION/VRAAG 9**

9.1

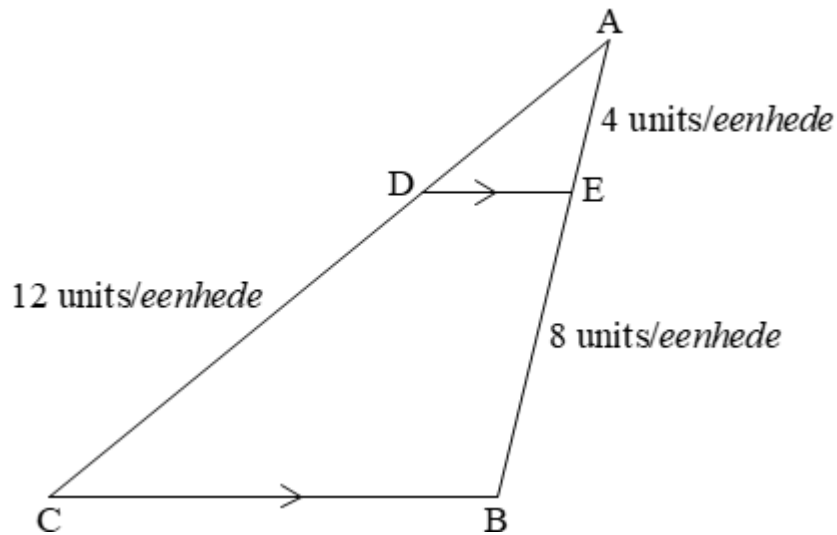

9.1.1	$\frac{AD}{CD} = \frac{AE}{BE}$ (Prop. Theorem / <i>Eweredigheid</i> ; $DE \parallel BC$ )	✓ <b>ST</b> ✓ <b>RE</b>	<b>A</b> <b>A</b> (2)
9.1.2	$\frac{AD}{CD} = \frac{AE}{BE}$ $\frac{AD}{12} = \frac{4}{8}$ $AD = \frac{4}{8} \times 12$ $= 6 \text{ units / eenhede}$	✓ <b>SF</b>  ✓ 6 <b>AO: Full marks/</b> <b><i>Volpunte</i></b>	<b>CA</b>  <b>CA</b>  (2)

9.2

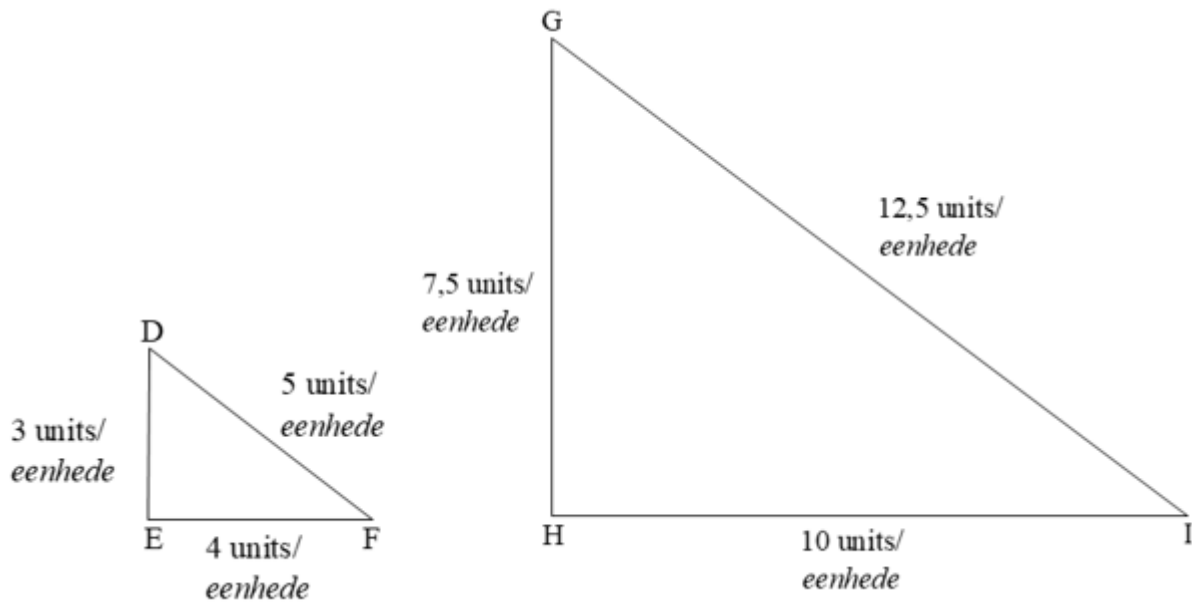

$\frac{DE}{GH} = \frac{3}{7,5} = \frac{2}{5} = 0,4 \text{ OR / OF } \frac{GH}{DE} = \frac{7,5}{3} = \frac{5}{2} = 2,5$	✓ Ratio/verhouding <b>A</b>
$\frac{EF}{HI} = \frac{4}{10} = \frac{2}{5} = 0,4 \text{ OR / OF } \frac{HI}{EF} = \frac{10}{4} = \frac{5}{2} = 2,5$	✓ Ratio/verhouding <b>A</b>
$\frac{DF}{GI} = \frac{5}{12,5} = \frac{2}{5} = 0,4 \text{ OR / OF } \frac{GI}{DF} = \frac{12,5}{5} = \frac{5}{2} = 2,5$	✓ Ratio/verhouding <b>A</b>
$\therefore \triangle DEF \parallel \triangle GHI \quad (\text{Sides in prop. / Sye in verhouding})$	✓ <b>RE</b> <b>A</b>
<b>OR / OF</b>	<b>OR / OF</b>
$\hat{E} = 90^\circ$ Conv. Pyth./ Omg. Pyth.	✓ Conv. Pyth./ Omg. Pyth. <b>A</b>
$\hat{H} = 90^\circ$ Conv. Pyth./ Omg. Pyth.	✓ Conv. Pyth./ Omg. Pyth. <b>A</b>
$\tan \hat{F} = \frac{3}{4}$ $\tan \hat{I} = \frac{3}{4}$	✓ Any trig ratio/ Enige trig verhouding <b>A</b>
$\hat{F} = 36,87^\circ$ $\hat{I} = 36,87^\circ$	
$\hat{E} = \hat{H}$ (Proven / Bewys)	✓ <b>ST</b> <b>A</b>
$\hat{F} = \hat{I}$ (Proven / Bewys)	✓ <b>RE</b> <b>A</b>
$\triangle DEF \parallel \triangle GHI \quad (\angle; \angle; \angle)$	✓ <b>RE</b> <b>A</b>
	<b>(4)</b>
	<b>[8]</b>

**QUESTION/VRAAG 10**

10.1

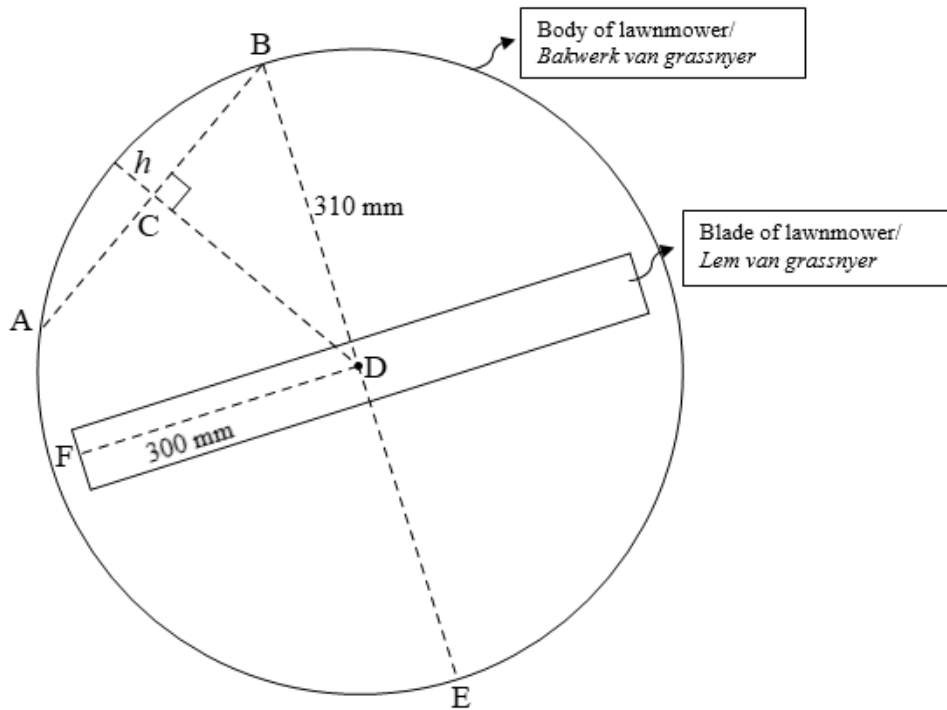

<p>10.1.1</p>	$\omega = 2\pi n$ $377 = 2\pi n$ $n = \frac{377}{2\pi} \text{ or / of } 60 \text{ rev / s}$	<p>✓ <b>F</b>                    <b>A</b></p> <p>✓ <b>SF</b>                    <b>A</b></p> <p>✓ <math>\frac{377}{2\pi}</math> or / of 60 <b>CA</b></p> <p><b>NPU</b></p> <p><b>NPR</b></p> <p style="text-align: right;">(3)</p>
<p>10.1.2</p>	$v = \omega r$ $= (377)(300)$ $= 113100 \text{ mm / s}$ <p style="text-align: center;"><b>OR / OF</b></p> $v = \pi Dn$ $= \pi (600) \left( \frac{377}{2\pi} \right) \text{ OR / OF } \approx \pi (600)(60)$ $= 113100 \text{ mm / s} \qquad \approx 113097,34 \text{ mm / s}$	<p>✓ <b>F</b>                    <b>A</b></p> <p>✓ <b>SF</b>                    <b>A</b></p> <p>✓ value of/waarde van v                    <b>CA</b></p> <p style="text-align: center;"><b>OR / OF</b></p> <p>✓ <b>F</b>                    <b>A</b></p> <p>✓ <b>SF</b>                    <b>CA</b></p> <p>✓ value of/waarde van v                    <b>CA</b></p> <p><b>NPU</b></p> <p><b>NPR</b></p> <p style="text-align: right;">(3)</p>

<p>10.1.3</p>	$4h^2 - 4dh + x^2 = 0$ $4h^2 - 4(620)h + (130)^2 = 0$ $4h^2 - 2480h + 16900 = 0$ $h = \frac{2480 \pm \sqrt{5880000}}{8}$ $h \approx 613,11 \text{ mm or / of } h \approx 6,89 \text{ mm}$ $\therefore \text{ minor / klein } h \approx 6,89 \text{ mm}$ <p style="text-align: center;"><b>OR / OF</b></p> $AC = BC = 65 \left( \begin{array}{l} \text{Line from centre of circle, perp. to chord} \\ \text{Lyn mdpt. sirkel, loodreg op koord} \end{array} \right)$ $CD^2 = 310^2 - 65^2$ $CD = 303,11 \text{ mm}$ $h = 310 - 303,11$ $h = 6,89 \text{ mm}$	<p>✓ <b>F</b> <b>A</b></p> <p>✓ <b>SF</b> <b>A</b></p> <p>✓ <b>S</b> <b>CA</b></p> <p>✓ both vertical heights/beide vertikale hoogtes <b>CA</b></p> <p>✓ minor height / klein hoogte <b>CA</b></p> <p style="text-align: center;"><b>OR / OF</b></p> <p>✓ <b>BC = 65</b> <b>A</b></p> <p>✓ <b>M</b> <b>A</b></p> <p>✓ Length/lengte CD <b>CA</b></p> <p>✓ <b>M</b> <b>A</b></p> <p>✓ minor height / klein hoogte <b>CA</b></p> <p><b>NPU</b></p> <p><b>NPR</b></p> <p style="text-align: right;"><b>(5)</b></p>
---------------	---	---

10.2

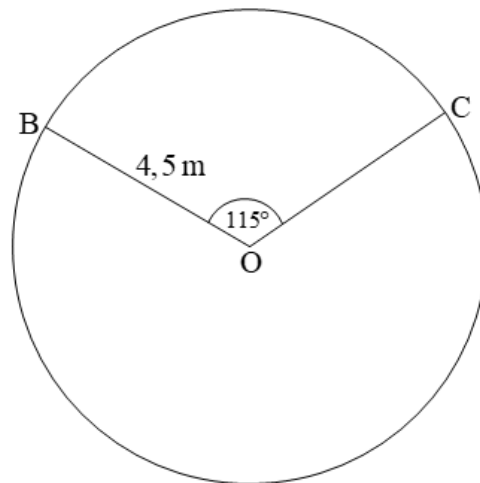

10.2.1	$\hat{BOC} = 115^\circ \times \frac{\pi}{180^\circ}$ $= \frac{23}{36} \pi \approx 2,01 \text{ rad}$	$\checkmark \frac{23}{36} \pi \text{ or/of } 2,01 \text{ A}$ <p style="text-align: right;">(1)</p> <b>NPU</b> <b>NPR</b>
--------	---	---

<p>10.2.2</p>	$\text{Area} = \frac{r^2 \theta}{2}$ $= \frac{(4,5)^2 \left( \frac{23}{36} \pi \right)}{2} \quad \text{OR / OF} \quad \frac{(4,5)^2 (2,01)}{2}$ $= \frac{207}{32} \pi \approx 20,32 \text{ m}^2 \quad \approx 20,35 \text{ m}^2$ <p style="text-align: center;"><b>OR/OF</b></p> $\text{Area} = \frac{115^\circ}{360^\circ} \times \pi r^2$ $= \frac{115^\circ}{360^\circ} \times \pi (4,5)^2$ $= \frac{207}{32} \pi \approx 20,32 \text{ m}^2$ <p style="text-align: center;"><b>OR/OF</b></p> $s = r \theta$ $= 4,5 \left( \frac{23}{36} \pi \right) \quad \text{OR / OF} \quad = 4,5 (2,01)$ $= \frac{23}{8} \pi \approx 9,03 \text{ m} \quad \approx 9,05 \text{ m}$ $\text{Area} = \frac{r s}{2}$ $= \frac{4,5 \left( \frac{23}{8} \pi \right)}{2} \quad \text{OR / OF} \quad \frac{4,5 (9,05)}{2}$ $= \frac{207}{32} \pi \approx 20,32 \text{ m}^2 \quad \approx 20,36 \text{ m}^2$	<p>✓ <b>F</b>                    <b>A</b></p> <p>✓ <b>SF</b>                    <b>CA</b></p> <p>✓ area/oppervlak <b>CA</b></p> <p style="text-align: center;"><b>OR/OF</b></p> <p>✓ <b>F</b>                    <b>A</b></p> <p>✓ <b>SF</b>                    <b>A</b></p> <p>✓ area/oppervlak <b>CA</b></p> <p style="text-align: center;"><b>OR/OF</b></p> <p>✓ arc length/booglengte <b>CA</b></p> <p>✓ <b>F</b>                    <b>A</b></p> <p>✓ area/oppervlak <b>CA</b></p> <p><b>NPR</b> <b>NPU</b></p> <p style="text-align: right;">(3)</p>
---------------	---	--

10.2.3  
 #

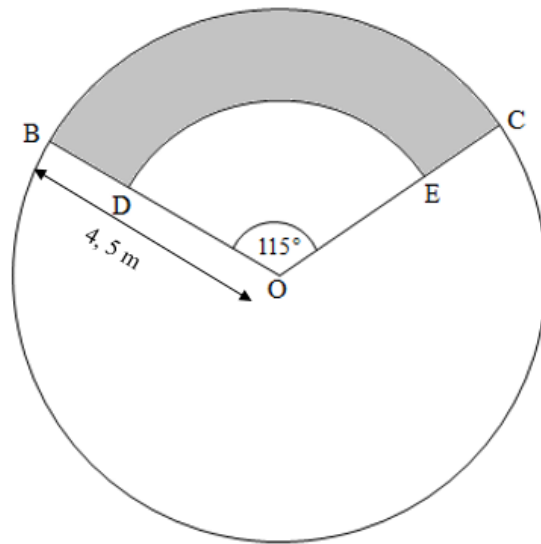

$DO = \frac{3}{5} \times 4,5 = 2,7 \text{ m}$ $A_{DOE} = \frac{(2,7)^2 \left( \frac{23}{36} \pi \right)}{2} \quad \text{OR / OF} \quad A_{DOE} = \frac{115^\circ}{360^\circ} \times \pi (2,7)^2$ $= \frac{1863}{800} \pi \approx 7,32 \text{ m}^2$ $A_{\text{shaded/geskakeer}} = \frac{207}{32} \pi - \frac{1863}{800} \pi$ $= \frac{207}{50} \pi \approx 13,01 \text{ m}^2$ <p><math>\therefore</math> Seedlings needed / Saailinge benodig  <math>= 13 \times 4</math>  <math>= 52</math></p> <p style="text-align: center;"><b>OR/OF</b></p>	<p>✓ ratio/verhouding <b>A</b></p> <p>✓ length of/lengte van DO <b>CA</b></p> <p>✓ Area of/Oppv. van DOE <b>CA</b></p> <p>✓ Area of the shaded part/Oppv. van geskakeerde gedeelte <b>CA</b></p> <p>✓ Number of seedlings/Aantal saailinge <b>CA</b></p> <p style="text-align: center;"><b>OR/OF</b></p>
--	--

	$DO = \frac{3}{5} \times 4,5 = 2,7 \text{ m}$ $s_{DE} = r\theta$ $= 2,7 \left( \frac{23}{36} \pi \right)$ $= \frac{69}{40} \pi \approx 5,42 \text{ m}$ $\text{Area}_{DOE} = \frac{rs}{2}$ $= \frac{2,7 \left( \frac{69}{40} \pi \right)}{2}$ $= \frac{1863}{800} \pi \approx 7,32 \text{ m}^2$ $A_{\text{shaded/geskakeer}} = \frac{207}{32} \pi - \frac{1863}{800} \pi$ $= \frac{207}{50} \pi \approx 13,01 \text{ m}^2$ <p>∴ Seedlings needed / Saailinge benodig</p> $= 13 \times 4$ $= 52$	<p>✓ ratio/verhouding <b>A</b></p> <p>✓ length of/<u>lengte</u> van DO <b>CA</b></p> <p>✓ Area of/<i>Oppv.</i> van DOE <b>CA</b></p> <p>✓ Area of the shaded part/<i>Oppv. van geskakeerde gedeelte</i> <b>CA</b></p> <p>✓ Number of seedlings/<i>Aantal saailinge</i> <b>CA</b></p> <p><b>NPU</b> <b>NPR</b></p> <p>(5)</p> <p><b>[20]</b></p>
--	--	---

**QUESTION/VRAAG 11**

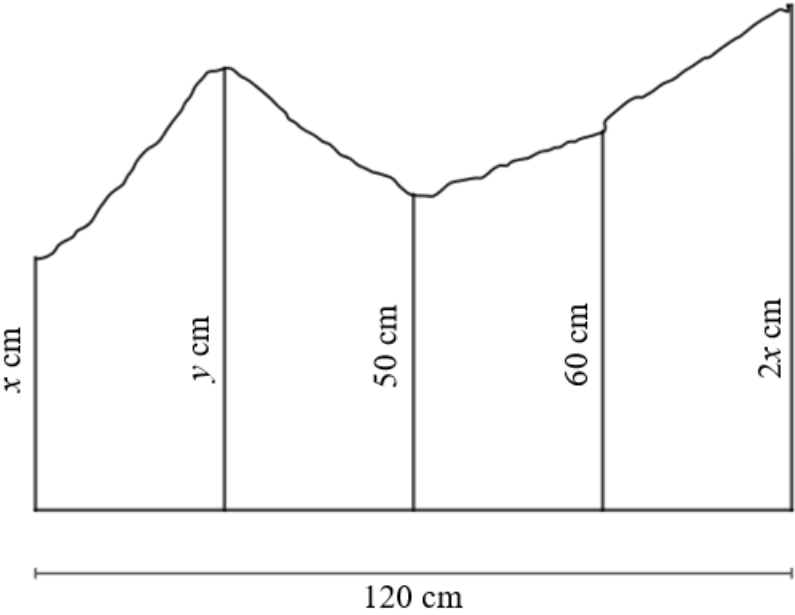
<p>11.1</p>			
<p>11.1.1</p>	<p>30 cm</p>	<p>✓ 30 cm</p>	<p><b>A</b> (1)</p>
<p>11.1.2</p>	<p><math>y = 50 + 20 = 70</math> cm</p>	<p>✓ value of/waarde van <math>y</math></p>	<p><b>A</b> (1)</p>
<p>11.1.3</p>	<p><math>A_T = a \left( \frac{o_1 + o_n}{2} + o_2 + o_3 + \dots + o_{n-1} \right)</math></p> <p><math>7200 = 30 \left( \frac{x + 2x}{2} + 70 + 50 + 60 \right)</math></p> <p><math>240 = 1,5x + 180</math></p> <p><math>\therefore x = 40</math> cm</p> <p style="text-align: center;"><b>OR / OF</b></p> <p><math>A_T = a (m_1 + m_2 + m_3 + \dots + m_n)</math></p> <p><math>7200 = 30 \left( \frac{x + 70}{2} + \frac{70 + 50}{2} + \frac{50 + 60}{2} + \frac{60 + 2x}{2} \right)</math></p> <p><math>240 = 1,5x + 180</math></p> <p><math>\therefore x = 40</math> cm</p>	<p>✓ <b>F</b></p> <p>✓ <b>SF</b></p> <p>✓ <b>S</b></p> <p>✓ value of /waarde van <math>x</math></p> <p style="text-align: center;"><b>OR / OF</b></p> <p>✓ <b>F</b></p> <p>✓ <b>SF</b></p> <p>✓ <b>S</b></p> <p>✓ value of /waarde van <math>x</math></p>	<p><b>A</b></p> <p><b>CA</b></p> <p><b>CA</b></p> <p><b>CA</b></p> <p><b>A</b></p> <p><b>CA</b></p> <p><b>CA</b></p> <p><b>CA</b> (4)</p>

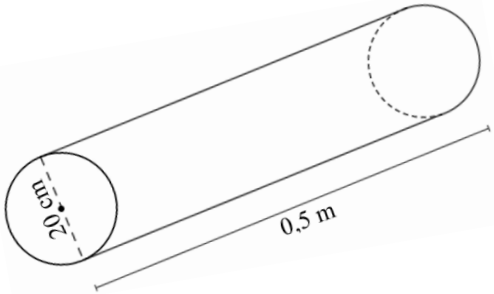
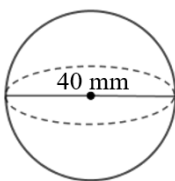
11.2		
11.2.1	$0,5 \text{ m} \times 100 = 50 \text{ cm}$	✓ 50 cm <span style="float: right;">A (1)</span>
11.2.2	$r = 40 \div 2 = 20 \text{ mm}$ $\therefore r = 20 \div 10 = 2 \text{ cm}$  <p style="text-align: center;"><b>OR / OF</b></p> $d = 40 \div 10 = 4 \text{ cm}$ $\therefore r = 4 \div 2 = 2 \text{ cm}$	✓ M $40 \div 2$ <span style="float: right;">A</span> ✓ $r$ value in/waarde in cm <span style="float: right;">CA</span>  <p style="text-align: center;"><b>OR / OF</b></p> ✓ M <span style="float: right;">A</span> ✓ $r$ value/waarde in cm <span style="float: right;">CA</span> <b>AO: Full marks/Volpunte</b> <span style="float: right;">(2)</span>
11.2.3	TSA of Cylindrical rod / <i>Buite-oppervlakte van silindriese staaf:</i> $= 2\pi r^2 + 2\pi rh$ $= 2\pi(10)^2 + 2\pi(10)(50)$ $= 1200\pi \approx 3769,91 \text{ cm}^2$	✓ SF <span style="float: right;">CA</span> ✓ total surface area/ <i>totale buite-oppervlakte</i> <span style="float: right;">CA (2)</span>

<p>11.2.4</p>	<p>Volume of one steel ball bearing/<i>van een staal bal</i></p> $= \frac{4}{3} \pi (2)^3$ $= \frac{32}{3} \pi \approx 33,51 \text{ cm}^3$ <p>Volume of Cylindrical rod/<i>van silindriese staaf</i></p> $= \pi (10)^2 (50)$ $= 5000 \pi \approx 15707,96 \text{ cm}^3$ <p>Volume Recovered / <i>Herwin</i></p> $= 5000\pi - 18\% \times 5000\pi \quad \text{OR / OF}$ $= 82\% \times 5000\pi$ $= 4100 \pi$ $\approx 12880,53 \text{ cm}^3$ $\therefore \frac{4100 \pi}{\frac{32}{3} \pi} \qquad \qquad \qquad \therefore \frac{32}{3} \pi \times 400$ $= 384,375 \quad \text{OR / OF} \qquad \qquad \qquad = \frac{12800}{3} \pi$ $\approx 384 \qquad \qquad \qquad = 13404,13 \text{ cm}^3$ <p><math>\therefore</math> More than 400 balls can <b>NOT</b> be made / <i>Meer as 400 balle kan NIE gemaak word NIE.</i></p>	<p>✓ <b>SF</b> <span style="float:right"><b>CA</b></span></p> <p>✓ Vol. of ball bearing/<i>Vol. van staal koellaër</i> <span style="float:right"><b>CA</b></span></p> <p>✓ Vol. of cyl. rod/<i>Vol. van sil.staaf</i> <span style="float:right"><b>CA</b></span></p> <p>✓ <b>M</b> <span style="float:right"><b>A</b></span></p> <p>✓ Vol. recovered/<i>herwin</i> <span style="float:right"><b>CA</b></span></p> <p>✓ conclusion/<i>gevolgtrekking</i> <span style="float:right"><b>CA</b></span> (6)</p>
		<b>[17]</b>

**TOTAL/TOTAAL: 150**