

Confidential



basic education

Department:
Basic Education
REPUBLIC OF SOUTH AFRICA

**NATIONAL
SENIOR CERTIFICATE**

GRADE 12

MECHANICAL TECHNOLOGY: WELDING AND METALWORK

NOVEMBER 2025

MARKS: 200

TIME: 3 hours

This question paper consists of 15 pages and a 2-page formula sheet.

INSTRUCTIONS AND INFORMATION

1. Write your centre number and examination number in the spaces provided on the ANSWER BOOK.
2. Read ALL the questions carefully.
3. Answer ALL the questions.
4. Number the answers correctly according to the numbering system used in this question paper.
5. Start EACH question on a NEW page.
6. Show ALL calculations and units. Round off final answers to TWO decimal places.
7. Candidates may use non-programmable scientific calculators and drawing instruments.
8. The value of gravitational acceleration should be taken as 9,81 m/s² or 10 m/s².
9. ALL dimensions are in millimetres, unless stated otherwise in the question.
10. Write neatly and legibly.
11. A formula sheet is attached at the end of the question paper.
12. Use the criteria below to assist you in managing your time.

QUESTION	CONTENT	MARKS	TIME IN MINUTES
	GENERIC		
1	Multiple-choice Questions	6	6
2	Safety	10	10
3	Materials	14	14
	SPECIFIC		
4	Multiple-choice Questions	14	10
5	Terminology (Templates)	23	20
6	Tools and Equipment	18	10
7	Forces	45	40
8	Joining Methods (Weld Inspection)	23	20
9	Joining Methods (Stresses and Distortion)	18	20
10	Maintenance	8	10
11	Terminology (Development)	21	20
TOTAL		200	180

QUESTION 1: MULTIPLE-CHOICE QUESTIONS (GENERIC)

Various options are provided as possible answers to the following questions. Choose the answer and write only the letter (A–D) next to the question numbers (1.1 to 1.6) in the ANSWER BOOK, e.g. 1.7 E.

- 1.1 Which ONE of the following refers to the code of good practice on HIV/Aids and employment? (1)
- A Employers can simply dismiss a person who has HIV/Aids.
 - B It does not elaborate on how everybody has the right to fair labour practices regarding HIV/Aids.
 - C It contains the daily working hours of employees.
 - D It contains common guidelines on how employers, employees and trade unions should respond to HIV/Aids in the workplace.
- 1.2 Who is responsible for the provision of PPE in the workshop? (1)
- A Employee
 - B Cleaning staff
 - C Foreman
 - D Employer
- 1.3 The function of the finger protector in the power-driven guillotine is to prevent the operators from ... (1)
- A reaching below the hold-down guards.
 - B touching revolving parts.
 - C getting their clothes caught in the machine.
 - D bending the work piece.
- 1.4 FIGURE 1.4 below shows a spark test being conducted. Identify the type of material with reference to the spark pattern. (1)

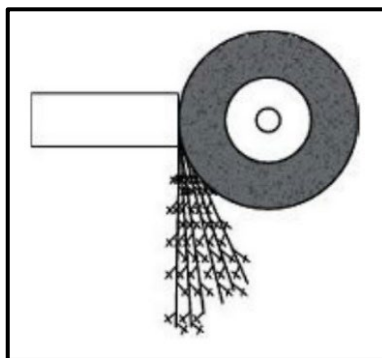

FIGURE 1.4

- A Copper
 - B Brass
 - C High-carbon steel
 - D Aluminium alloy
- (1)

- 1.5 The hardening temperature depends on the ... of the steel.
- A carbon content
 - B malleability
 - C size
 - D weight
- (1)
- 1.6 What determines the properties of steel during heat treatment?
- A The melting point
 - B Type of grain structure
 - C The water content of the metal
 - D The molten state of the metal
- (1)
[6]

QUESTION 2: SAFETY (GENERIC)

- 2.1 State TWO visible signs on an injured person that a first-aider must take note of before treatment. (2)
- 2.2 State TWO safety measures to be considered BEFORE arc welding can be performed. (2)
- 2.3 State TWO safety rules that must be adhered to BEFORE switching on a portable angle grinder. (2)
- (NOTE: All PPE has already been taken care of.) (2)
- 2.4 State TWO safety rules when handling oxy-acetylene gas cylinders. (2)
- 2.5 State ONE disadvantage of the product layout. (1)
- 2.6 State ONE general duty every employee must adhere to in the workplace according to the Occupational Health and Safety Act (OHSA), 1993 (Act 85 of 1993). (1)
- [10]**

QUESTION 3: MATERIALS (GENERIC)

- 3.1 What will be the effect on the following materials when conducting a bend test?
- 3.1.1 Mild steel (1)
 - 3.1.2 High-carbon steel (1)
- 3.2 What is the purpose of heat treatment of metals? (1)
- 3.3 State THREE quenching media used in the heat treatment of steel. (3)

- 3.4 Which TWO methods are used to conduct a sound test to identify metals? (2)
- 3.5 What is the purpose of case hardening of steel during heat treatment? (2)
- 3.6 Name TWO common methods of case hardening. (2)
- 3.7 Explain the reason for normalising steel during heat treatment. (2)
- [14]**

QUESTION 4: MULTIPLE-CHOICE QUESTIONS (SPECIFIC)

Various options are provided as possible answers to the following questions. Choose the answer and write only the letter (A–D) next to the question numbers (4.1 to 4.14) in the ANSWER BOOK, e.g. 4.15 E.

4.1 When are lattice girders used?

- A In long-span applications
- B In angled applications
- C In short-span applications
- D In high-pitched roofs

(1)

4.2 What does **G**, shown in FIGURE 4.2 below, represent?

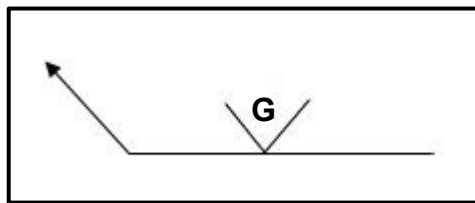

FIGURE 4.2

- A Grease
- B Grind
- C Guard
- D Guillotine

(1)

4.3 Which ONE of the following is used to move the ram in a hydraulic press?

- A Air
- B Water
- C Oil
- D Petrol

(1)

4.4 FIGURE 4.4 below shows a section of a roof truss. Identify part **X**.

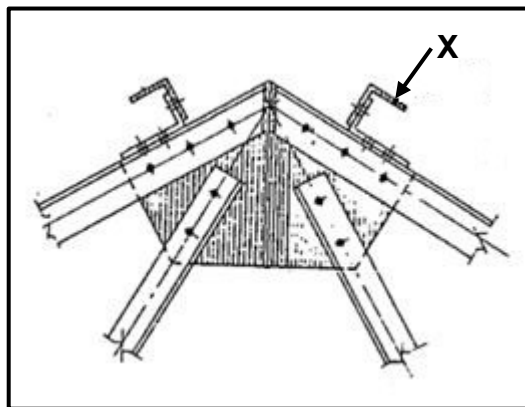

FIGURE 4.4

- A Top flange
- B Purlin
- C Ridging
- D Gusset plate

(1)

4.5 The purpose of inert gas in MIGS/MAGS welding is to ...

- A hold a work piece together during welding.
- B protect the flux-coated electrode.
- C create a molten pool for electrode feed.
- D shield the molten pool from atmospheric gases.

(1)

4.6 Identify the welding machine shown in FIGURE 4.6 below.



FIGURE 4.6

- A Arc welding machine
- B Spot welding machine
- C Gas welding machine
- D MIG welding machine

(1)

4.7 FIGURE 4.7 below shows the stress-strain diagram obtained during a tensile test on mild steel. What is indicated by **S** in the diagram?

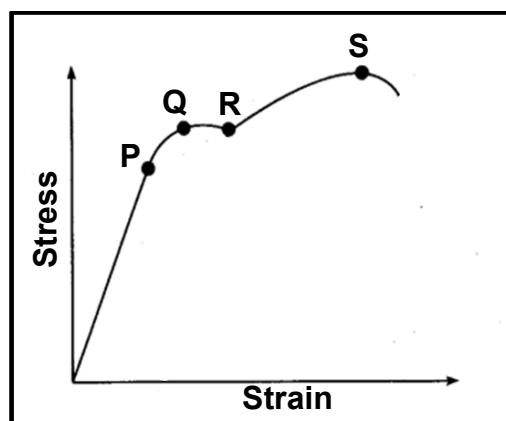

FIGURE 4.7

- A Maximum stress
- B Break stress
- C Elasticity limit
- D Yield point

(1)

- 4.8 Which ONE of the following determines the effect on shrinkage when performing arc welding?
- A Amount of gas
 - B Surface area
 - C Type of electrode
 - D Type of spark
- (1)
- 4.9 What type of structure forms on the exterior of a metal immediately after cooling when a high-carbon steel is heated to its austenitic temperature and cooled quickly in cold water?
- A Ferrite
 - B Pearlite
 - C Cementite
 - D Martensite
- (1)
- 4.10 Which ONE of the following is the CORRECT description for original length?
- A Ratio between stress and strain
 - B Length by which an object is shortened or lengthened
 - C Length of an object before an external load is applied
 - D Length of an object after an external load is applied
- (1)
- 4.11 When temperature at 720 °C remains constant for a time period during soaking in the heat-treatment process, it is known as the ... point.
- A decalescent
 - B melting
 - C cooling
 - D heating
- (1)
- 4.12 Identify the test shown in FIGURE 4.12 below.

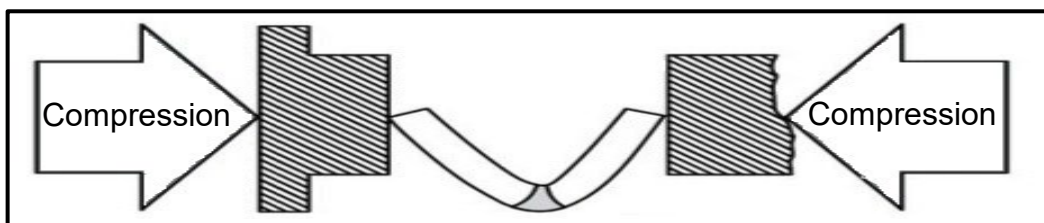

FIGURE 4.12

- A Nick-break test
 - B Free-bend test
 - C X-ray test
 - D Ultrasonic test
- (1)

4.13 What is the colour of the acetylene gas cylinder?

- A Maroon
- B Grey
- C Black
- D Green

(1)

4.14 Which ducting section is shown in FIGURE 4.14 below?

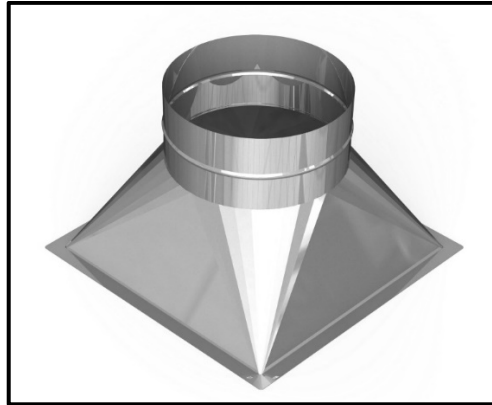

FIGURE 4.14

- A Pyramid
- B Truncated prism
- C Transformer
- D Hexagonal joint

(1)
[14]

QUESTION 5: TERMINOLOGY (TEMPLATES) (SPECIFIC)

5.1 A brass ring must be manufactured using a 30 x 30 mm square bar. The ring has an inside diameter of 950 mm.

Calculate the following:

5.1.1 The mean diameter of the ring (2)

5.1.2 The mean circumference of the ring (Round off your answer to the nearest whole number.) (3)

5.2 Draw the fusion weld symbols for the following:

5.2.1 V-butt on the arrow side (2)

5.2.2 Flare-V on the other side (2)

5.3 Name THREE types of measuring hand tools that template makers use in a template loft. (3)

5.4 State the THREE types of templates used on channel iron, angle irons and I-beams. (3)

5.5 FIGURE 5.5 below shows a drawing with the relevant information needed to manufacture a component. Identify A–H.

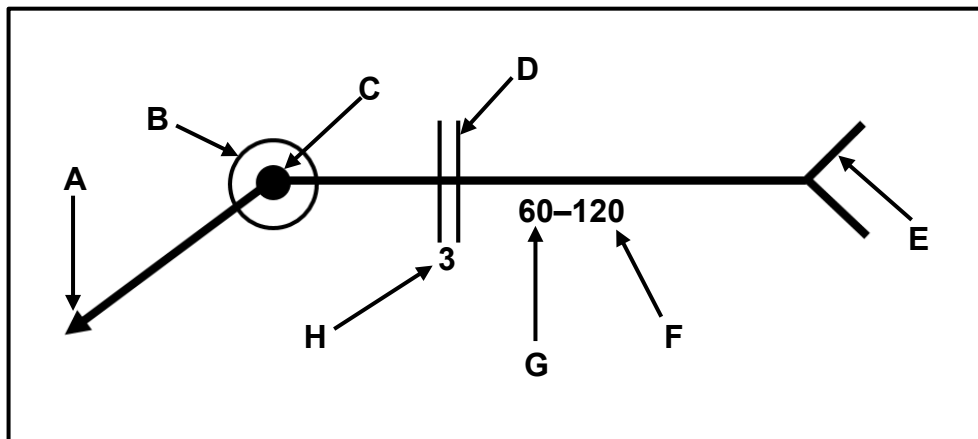

FIGURE 5.5

(8)
[23]

QUESTION 6: TOOLS AND EQUIPMENT (SPECIFIC)

6.1 FIGURE 6.1 below shows a portable angle grinder. Label **A–D**.

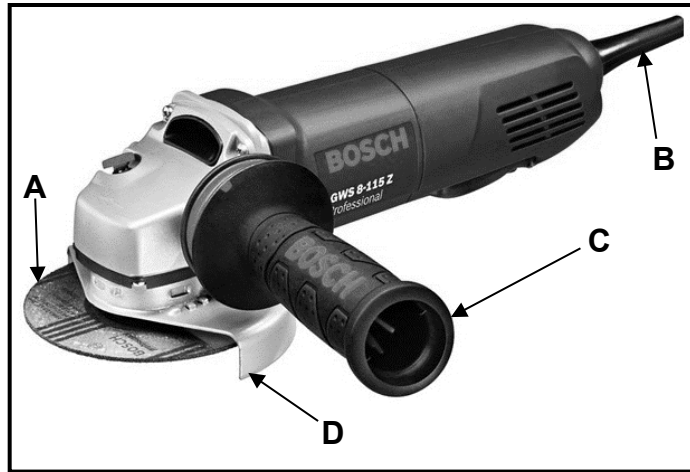

FIGURE 6.1

(4)

6.2 State the difference between the functions of a *power saw* and a *vertical band saw*. (2)

6.3 FIGURE 6.3 below shows an arc welding setup. Answer the questions that follow.

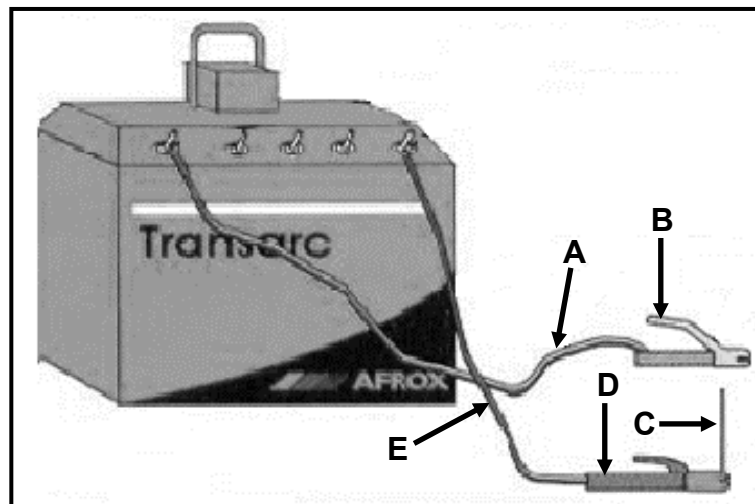

FIGURE 6.3

6.3.1 Label **A–E**. (5)

6.3.2 State the function of component **D**. (1)

6.4 Describe the operating principle of a manual guillotine. (3)

6.5 What is the press machine used for in the mechanical workshop? (3)

[18]

QUESTION 7: FORCES (SPECIFIC)

7.1 A tensile force of 85 kN is exerted onto a round bar with a cross-sectional area of 0,0962 m². The original length of the round bar is 2 000 mm.

Calculate the following:

7.1.1 The stress caused in the material in Pa (2)

7.1.2 The strain caused if the change in length of the bar is 0,05 mm (2)

7.2 FIGURE 7.2 below shows a uniform beam that is supported by two vertical supports, **RL** and **RR**. The beam is subjected to TWO point loads and a uniformly distributed load (UDL).

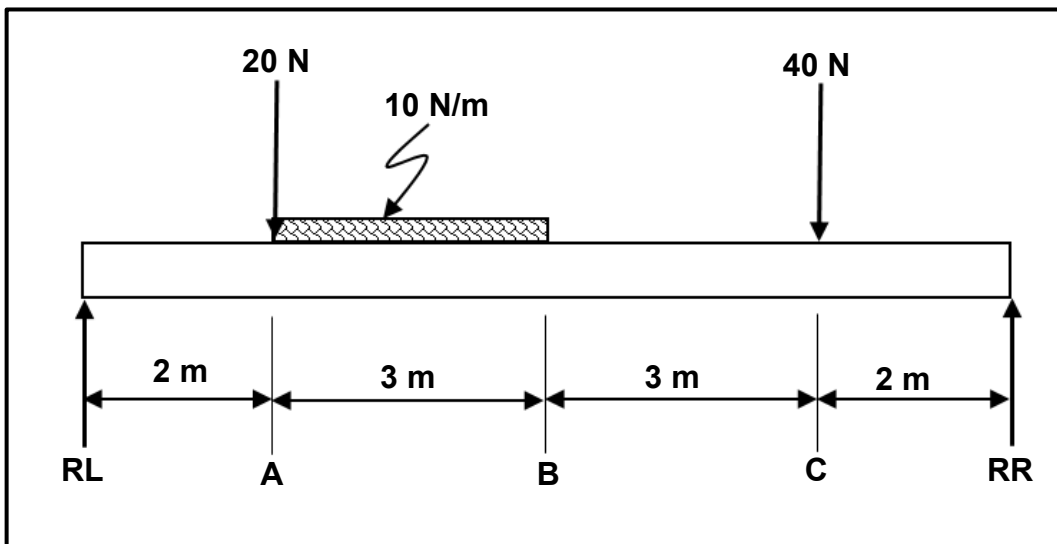

FIGURE 7.2

Calculate the following:

7.2.1 The magnitude of the point load representing the UDL (2)

7.2.2 The reactions in **RL** and **RR** (8)

7.2.3 The bending moments at **A**, **B** and **C** (5)

7.2.4 Draw the bending moment diagram.

Use the following scales:

- Beam length: 1 m = 10 mm
- Bending moment diagram: 1 Nm = 1 mm (5)

7.3 FIGURE 7.3 below shows a roof truss for a warehouse. Study the diagram and answer the questions that follow.

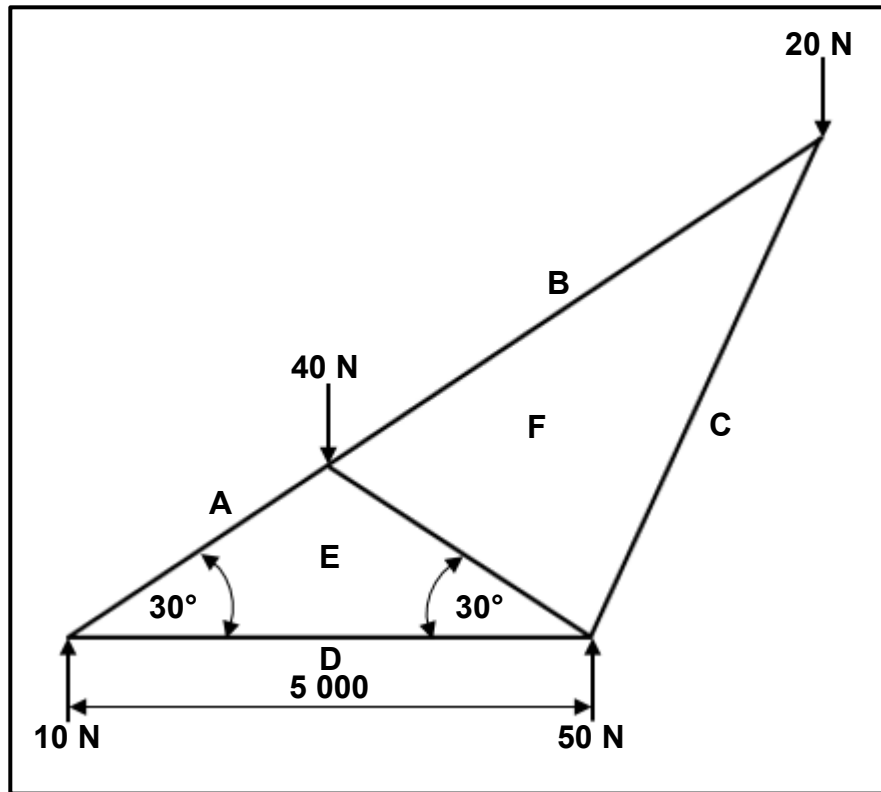

FIGURE 7.3

- 7.3.1 Draw the space diagram to scale 1 : 100. (6)
- 7.3.2 Draw the vector diagram to scale 1 N = 2 mm. (5)
- 7.3.3 Determine the magnitude of the forces in members **AE**, **BF**, **CF**, **DE** and **EF**. Identify the members as struts or ties. (10)
- [45]**

QUESTION 8: JOINING METHODS (INSPECTION OF WELD) (SPECIFIC)

- 8.1 State THREE methods of preventing slag inclusion. (3)
- 8.2 Name THREE different types of cracks in welded joints. (3)
- 8.3 State TWO causes of undercutting during arc welding. (2)
- 8.4 State TWO factors to be considered during a machinability test on a welded joint. (2)
- 8.5 State TWO defects revealed after conducting a nick-break test. (2)
- 8.6 State THREE causes of blow holes in porosity. (3)
- 8.7 State TWO disadvantages of dye-penetrant testing. (2)
- 8.8 Explain the procedure to conduct an X-ray test. (6)
- [23]**

QUESTION 9: JOINING METHODS (STRESSES AND DISTORTION) (SPECIFIC)

- 9.1 State FOUR visual requirements during the visual inspection process of welded joints. (4)
- 9.2 State THREE factors that affect the cooling rate after welding. (3)
- 9.3 Describe the difference between *cold working* and *hot working* of steel. (4)
- 9.4 What is the function of strongbacks? (1)
- 9.5 Which heat-treatment process is used to soften metal? (1)
- 9.6 Define the term *elastic deformation*. (2)
- 9.7 State THREE types of shrinkage in welding. (3)
- [18]**

QUESTION 10: MAINTENANCE (SPECIFIC)

- 10.1 Discuss TWO reasons for locking out large machines before maintenance. (2)
- 10.2 Give the reason why multiple holes are found on tags. (2)
- 10.3 State TWO potential consequences of a lack of maintenance on a drill press. (2)
- 10.4 State TWO maintenance guidelines for a bench grinder. (2)
- [8]**

QUESTION 11: TERMINOLOGY (DEVELOPMENT) (SPECIFIC)

FIGURE 11.1 below shows a hopper with a vertical height (VH) of 600 mm. Answer the questions that follow.

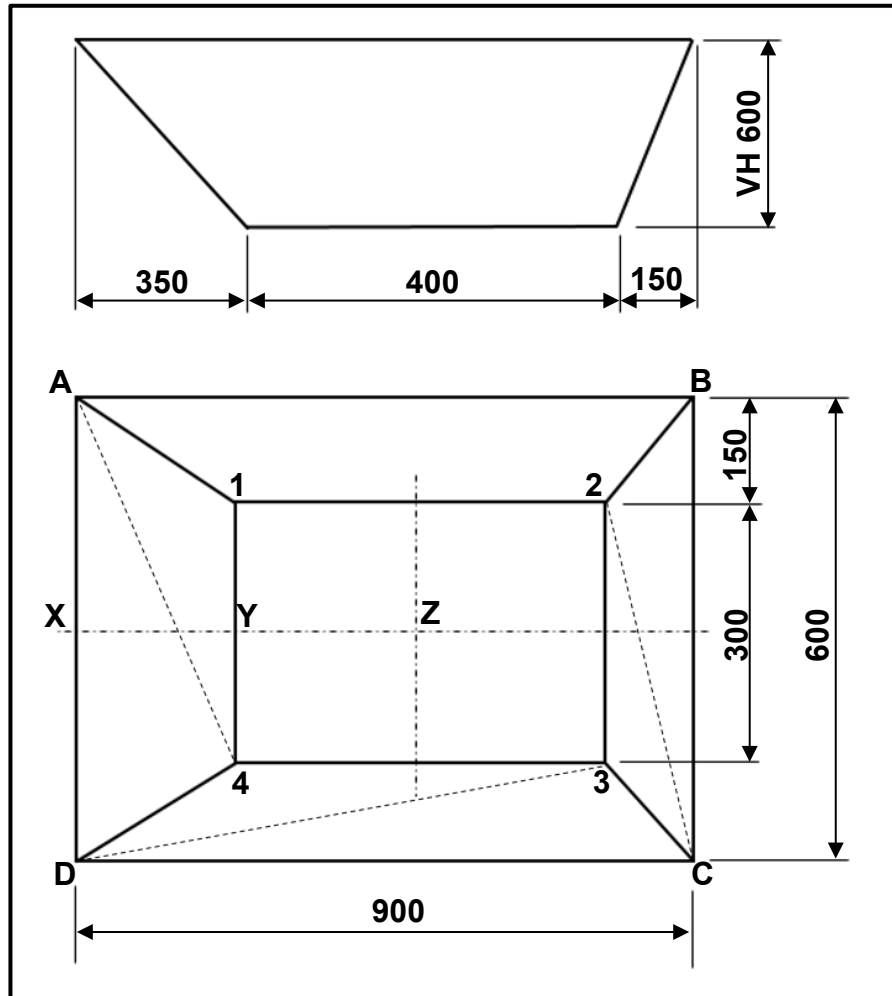

FIGURE 11.1

- 11.1 Identify the type of hopper above. (2)
- 11.2 Calculate the following true lengths in FIGURE 11.1:
- 11.2.1 **A-4** (5)
- 11.2.2 **C-2** (5)
- 11.2.3 **D-3** (5)
- 11.2.4 **X-Y** (2)
- 11.2.5 **X-Z** on the base of the hopper (plan length) (2)

[21]

TOTAL: 200

FORMULA SHEET FOR MECHANICAL TECHNOLOGY: WELDING AND METALWORK

1. STRESS AND STRAIN

$$1.1 \quad A_{\text{shaft}} = \frac{\pi d^2}{4}$$

$$1.2 \quad A_{\text{pipe}} = \frac{\pi(D^2 - d^2)}{4}$$

$$1.3 \quad \text{Safety factor} = \frac{\text{Maximum stress / Break stress}}{\text{Safe working stress}}$$

$$1.4 \quad \text{Stress} = \frac{\text{Force}}{\text{Area}} \quad \text{OR} \quad \sigma = \frac{F}{A}$$

$$1.5 \quad \text{Strain} = \frac{\text{Change in length}}{\text{Original length}} \quad \text{OR} \quad \varepsilon = \frac{\Delta L}{oL}$$

$$1.6 \quad \text{Young's modulus} = \frac{\text{Stress}}{\text{Strain}} \quad \text{OR} \quad E = \frac{\sigma}{\varepsilon}$$

2. PYTHAGORAS' THEOREM AND TRIGONOMETRY

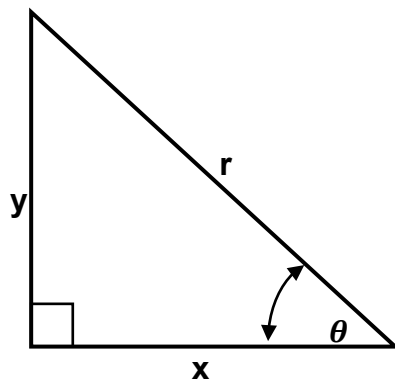

$$2.1 \quad \sin \theta = \frac{y}{r}$$

$$2.2 \quad \cos \theta = \frac{x}{r}$$

$$2.3 \quad \tan \theta = \frac{y}{x}$$

$$2.4 \quad r^2 = x^2 + y^2 \quad \text{OR} \quad a^2 = b^2 + c^2$$

3. TEMPLATES AND DEVELOPMENTS

3.1 $Mean \ \varnothing = Outside \ \varnothing - Plate \ thickness$ **OR** $Mean \ \varnothing = Inside \ \varnothing + Plate \ thickness$

3.2 $Mean \ circumference = \pi \times Mean \ \varnothing$

Where:

$$\varnothing = Diameter$$

4. SCREW THREADS

4.1 $Drill \ size = Outside \ \varnothing - Pitch$