



higher education & training

Department:
Higher Education and Training
REPUBLIC OF SOUTH AFRICA

NATIONAL CERTIFICATE METAL WORKERS' THEORY N1

(11022061)

**28 November 2023 (X-paper)
09:00–12:00**

Drawing instruments and nonprogrammable calculators may be used.

This question paper consists of 6 pages and 1 addendum.

140Q1E2328

DEPARTMENT OF HIGHER EDUCATION AND TRAINING
REPUBLIC OF SOUTH AFRICA
NATIONAL CERTIFICATE
METAL WORKERS' THEORY N1
TIME: 3 HOURS
MARKS: 100

INSTRUCTIONS AND INFORMATION

1. Answer all the questions.
 2. Read all the questions carefully.
 3. Number the answers according to the numbering system used in this question paper.
 4. Start each question on a new page.
 5. Use only a blue or black pen.
 6. Write neatly and legibly.
-

QUESTION 1: SAFETY AND HOUSEKEEPING

- 1.1 Which Act promotes safety in the workplace? (2)
- 1.2 Which human factor is the leading cause of accidents in the workplace? (1)
- 1.3 When erecting a scaffold, why is it necessary to ensure that the first run of bays is level? (1)
- 1.4 What must be worn by everyone erecting or working on a scaffold higher than 2 metres? (1)

[5]**QUESTION 2: CARE AND USE OF TOOLS**

- 2.1 State the uses of a straight-peen hammer and a cross-peen hammer. (2)
- 2.2 What must one ensure when using any type of spanner? (1)
- 2.3 State the purpose of the try square. (1)
- 2.4 Name THREE types of spanners used in the workshop. (3)
- 2.5 Explain how to adjust the folding steel rule to be able to measure an angle using the line of chords. (2)
- 2.6  Calculate the hypotenuse on an irregular plate, 12 mm thick, using Pythagoras' theorem, if the length of the plate is 2 500 mm and the width is 1 500 mm. The answer is to be given in metres.

HINT: $H^2 = X^2 + Y^2$

(3)

[12]**QUESTION 3: DEVELOPMENTS**

Use ADDENDUM A (attached) to answer this question. Drawing instruments must be used.

FIGURE 1 shows two views of a T-piece manufactured from two pipes of unequal diameters.

- 3.1 Construct the line of penetration between the two pipes. (2)
- 3.2 Show the shape of the hole in the main pipe. (2)
- 3.3 Calculate the circumference of the 38-mm diameter branch pipe. (2)
- 3.4 With the aid of drawing instruments, develop the pattern of the branch pipe. (4)

HINT: $C = 3,142 \times D$ 

Hand in ADDENDUM A on completion.

[10]

(11022061)

-4-

QUESTION 4: METALS, PLATES AND SECTIONS

4.1 Name TWO properties of each of the following metals:

4.1.1 Stainless steel

4.1.2 Aluminium



(2 × 2) (4)

4.2 Define the following terms:

4.2.1 Impact strength

4.2.2 Elasticity

4.2.3 Malleability

(3 × 1) (3)

4.3 State the full terms for the following abbreviations:

4.3.1 CL

4.3.2 OSU

4.3.3 mspl



(3 × 1) (3)

4.4 Give the names of the steel profiles shown below.

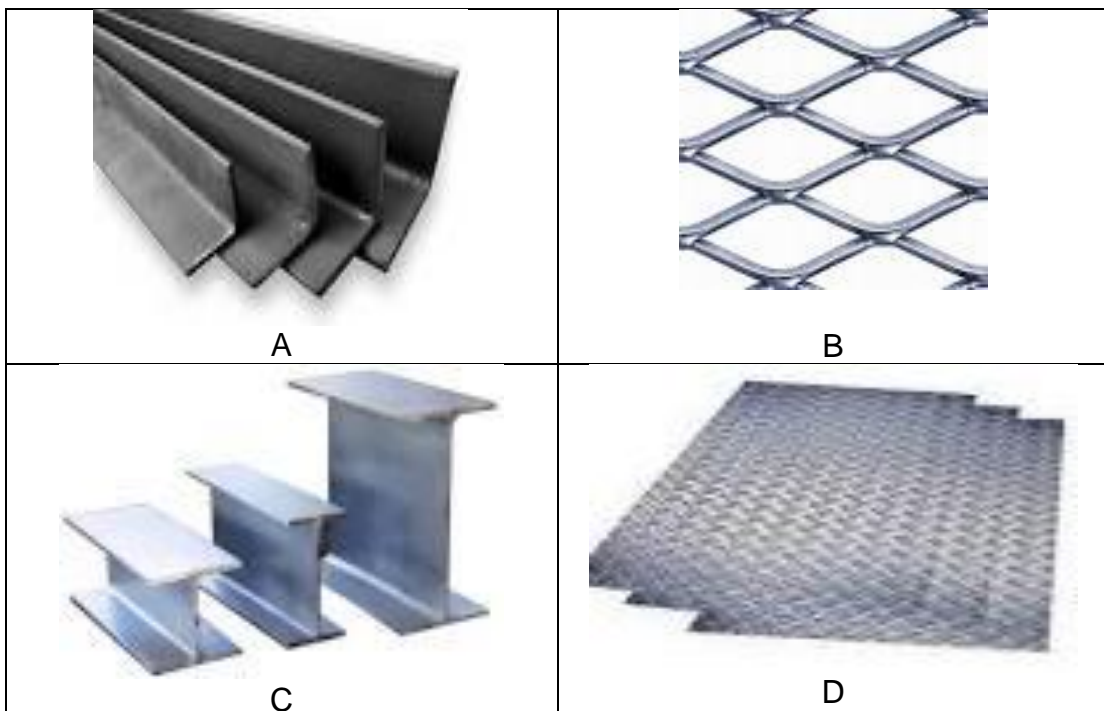

(4)
[14]

QUESTION 5: MACHINES

5.1 State the function of each of the following machines:

5.1.1 Pedestal drilling machine

5.1.2 Bending press

5.1.3 Horizontal bending roll

5.1.4 Guillotine

5.1.5 Circular power saw

(5 × 1)

(5)



5.2  Name FIVE safety precautions that should be considered before and during the use of angle and bench grinders.

(5)

[10]

QUESTION 6: JOINTS AND BOLTED JOINTS

6.1 Name the FOUR types of bolts commonly used in engineering work.

(4)

6.2 Two 10-mm flat bars must be joined by a 12-mm countersunk bolt. A washer 3 mm thick is to be used. Use 4 mm for the length of the two full threads.

Calculate the length of the countersunk bolt to be used and state the standard length of the bolt that will be used.

(4)

6.3 When and where is a black bolt used?

(2)

[10]

**QUESTION 7: ARC WELDING**

7.1 List any FIVE protective clothing that should be worn during arc welding, and state the reason why.

(10)

7.2  State FOUR disadvantages in using a DC welding machine compared to an AC welding machine.

(4)

[14]

QUESTION 8: OXYACETYLENE AND LPG CUTTING AND WELDING

8.1 Workers must wear the correct safety clothing when using oxyacetylene cutting or welding equipment to protect themselves from injury.



Name FIVE safety clothing that must be worn during the cutting and welding of oxyacetylene.

(5)

8.2 Name FOUR causes of backfire during gas welding and give a remedy for each.

(8)

8.3 What must be used to test for a leak on oxy-LPG or oxyacetylene equipment according to SANS 10.238 and where must it be applied?

(2)

[15]**QUESTION 9: CALCULATIONS AND PLANNING**

Calculate the length of an 80 mm x 8 mm flat bar required to make the pipe bracket as shown in FIGURE 2 below. Make a sketch of the pipe bracket before it is bent to the relevant sizes indicated on the sketch.

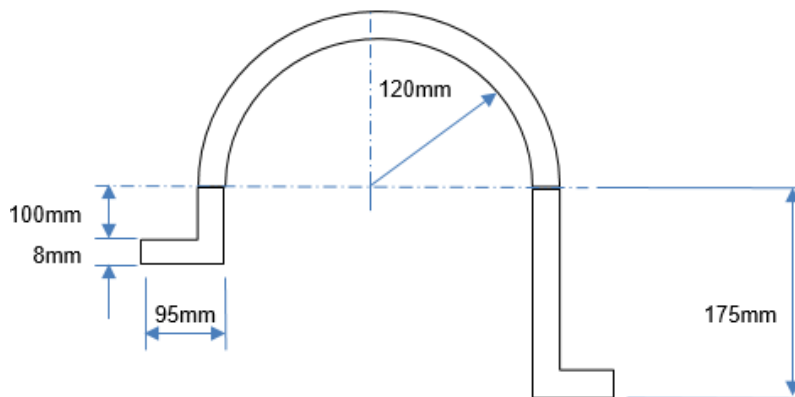
**FIGURE 2****[10]****TOTAL: 100**

(11022061)

ADDENDUM

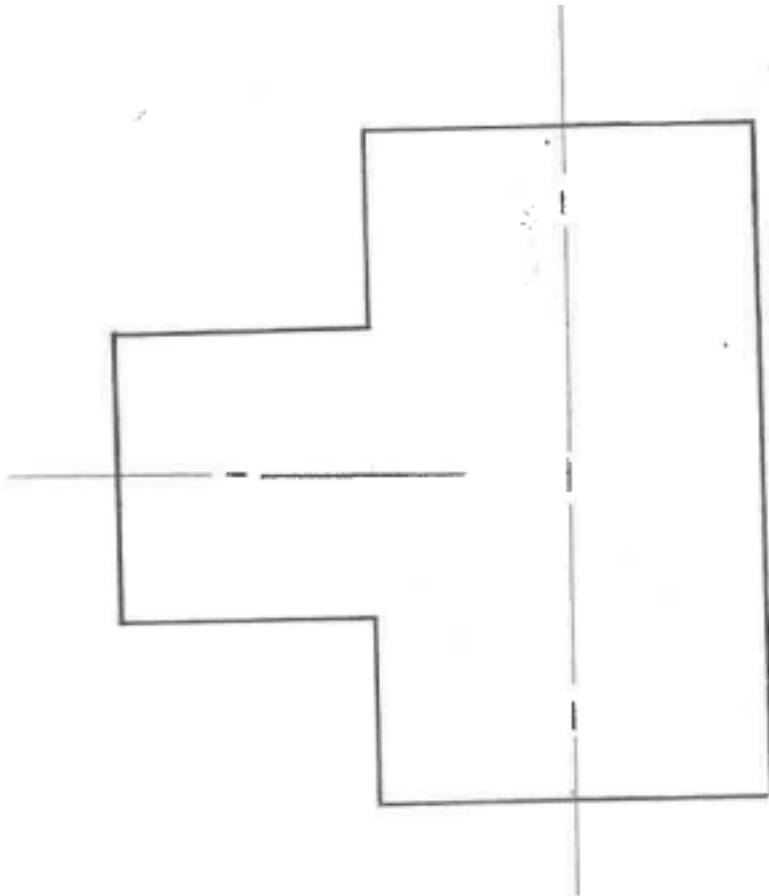

FIGURE 1