

TEACHERS WITHOUT BORDERS PROGRAMME

BROUGHT TO YOU BY



basic education

Department:
Basic Education
REPUBLIC OF SOUTH AFRICA

With grateful thanks to our associate partners, The [National Department of Basic Education](#), The [Independent Examinations Board](#), [Siyavula Education](#), [Smarticks](#), [Noteshare](#), [Lemonlicious](#), [datacentrix](#), and most of all, to the schools and teachers from both the public and private education sectors who as founder contributors, have lent content to the [Teachers without Borders programme](#), for the benefit of all South Africa's learners.

In Bill Gates words, at the Mandela Day 'Living Together' address: "Maintaining the quality of this country's higher education system while expanding access to more students will not be easy. But it's critical to South Africa's future" – working together, we can help achieve this."

Contributing schools to date:

Clifton School	Milnerton High	Rustenburg Girls' High	St Peter's
Durban Girls'	Northwood High	St Anne's DC	St Stithians
Fairmont High	Roedean	St John's DSG	Wynberg Boys' High
Herzlia High	Rondebosch Boys'	St Mary's DSG Kloof	Wynberg Secondary

**GRADE 9 PHYSICAL SCIENCES EXAM
JUNE 2019**

EXAMINER: Mrs M Greyling
MODERATOR: Mrs I Evans and Mrs K Storm

MARKS: 60
TIME: 60 Mins

Name: _____

CLASS: _____

You have been provided with a Data Sheet along with this exam paper, please make sure that you have one enclosed in your exam paper before you begin and that it is handed in along with your exam paper when the exam is completed.

QUESTION 1: Highlight or circle the correct answer to each of the following questions.

1.1 Potential energy is measured in.....

- A Ohms
- B Watts
- C Volts
- D Joules

1.2 The law of conservation of charge states:

- A Charge can be created but not destroyed, and transferred from one substance to another.
- B Charge cannot be created or destroyed, only transferred from one substance to another.
- C Charge can be created, destroyed and transferred from one substance to another.
- D Charge cannot be created, but destroyed and transferred from one substance to another.

1.3 Which of the following statements is **NOT** true regarding mass and weight?

- A Weight is a force caused by gravity and mass is the amount of matter in a substance.
- B Mass is measured in Kilograms and weight is measured in Newtons.
- C The weight of an object on the moon will be the same as the weight of the object on Earth.
- D The weight of an object on the moon will be less than the weight of the object on Earth.

1.4 Consider the following two circuits:

Circuit A

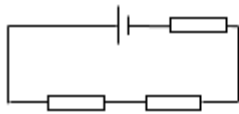

Circuit B

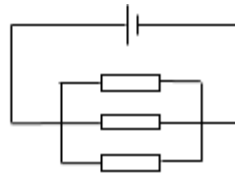

Which circuit has the lowest current flowing through it?

- A Circuit A
- B Circuit B
- C Both have the same current flowing through them
- D None of the above

1.5 A kettle's element releases 4500J of heat in 3 seconds. What is the kettle's power output?

- A 4500 W
- B 1500 J
- C 1500 W
- D 13500 W

[5]

QUESTION 2

Fill in the word needed to complete the following sentences.

- 2.1 _____ electricity involves electric charges which are stationary or at rest.
- 2.2 An object that has the same number of electrons as protons is said to be _____.
- 2.3 A _____ is a material that allows electric charge to flow freely through it.
- 2.4 Energy is defined as the ability to do _____.
- 2.5 The SI unit for power is the _____.

[5]

QUESTION 3

A balloon becomes charged and the image below shows a lady's hair being attracted to the charged balloon. Study the image and answer the questions that follow.



3.1 Describe **how** the balloon could become charged.

(3)

3.2 What force, contact or non-contact, is being demonstrated in the picture?

(1)

3.3 State the Law of Electrostatics.

(1)

[5]

QUESTION 4

Study the circuit below and answer the questions that follow.

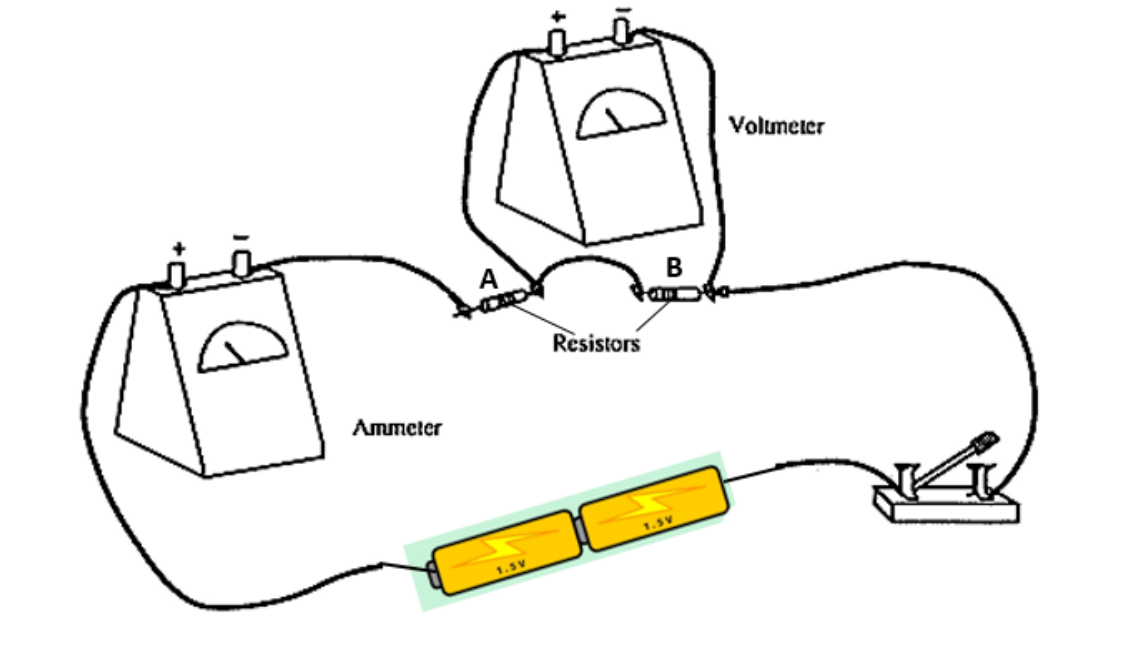

4.1 Draw a labelled circuit diagram to represent the above circuit.

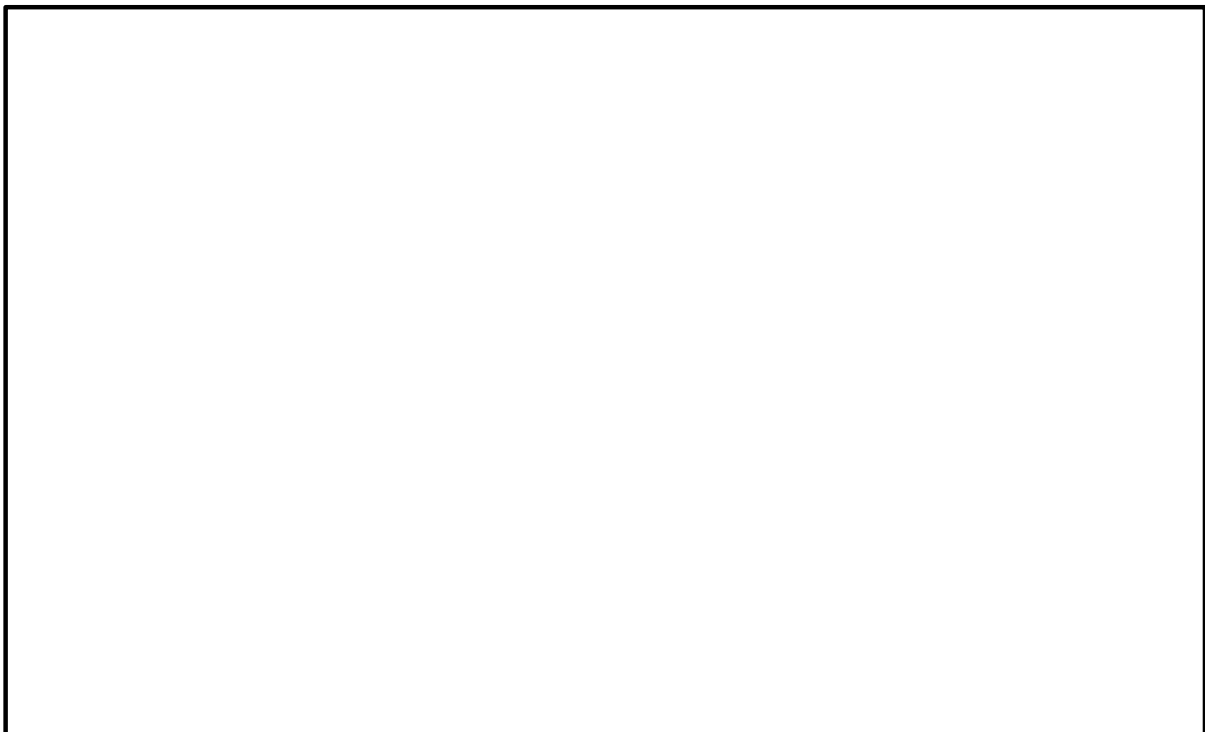

(5)

4.2 On your circuit diagram indicate the direction of CONVENTIONAL current.

(1)

4.3 If a resistor C is added in series to resistors A and B, what will happen to the reading on the voltmeter over resistor B?

_____ (1)

4.4 Give a reason for your answer to Question 4.3.

_____ (2)

4.5 Give ONE factor that affects the resistance of a metal conductor.

_____ (1)

[10]

QUESTION 5

Consider the circuit shown below and answer the questions that follow.

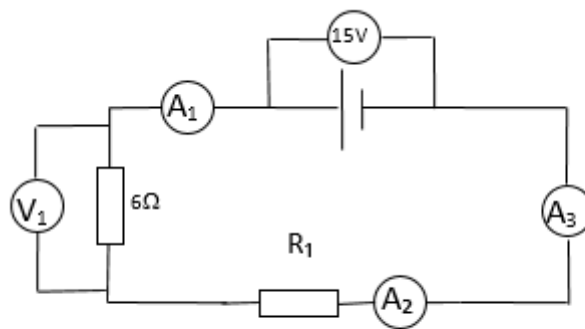

5.1 How will the reading on A₁ compare to the reading on A₂? Will it be more than, equal to, or less than the reading on A₂?

_____ (1)

5.2 If the resistance for R₁ is 2Ω, calculate the total resistance in the circuit.

_____ (1)

5.3 Calculate the reading on A₃. Round your answer off to 1 decimal place.

(3)

5.4 Calculate the reading on V_1 .

(3)

5.5 Calculate how much charge flows through the cell in 2 minutes.

(3)

[11]

QUESTION 6

You have set up 1000 Christmas lights on your Christmas tree. When you plug them in you discover that 5 of the lights are not working.

6.1 Are the lights connected in series or parallel?

[1]

QUESTION 7

The diagrams below show the forces acting in four different situations, A - C. Study the diagrams and answer the questions that follow.

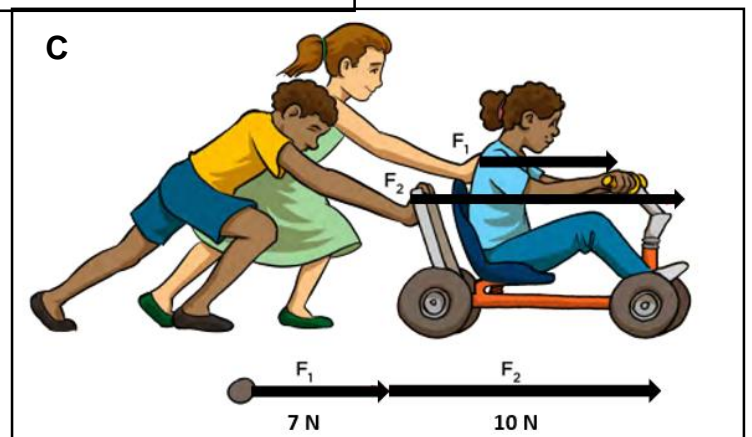
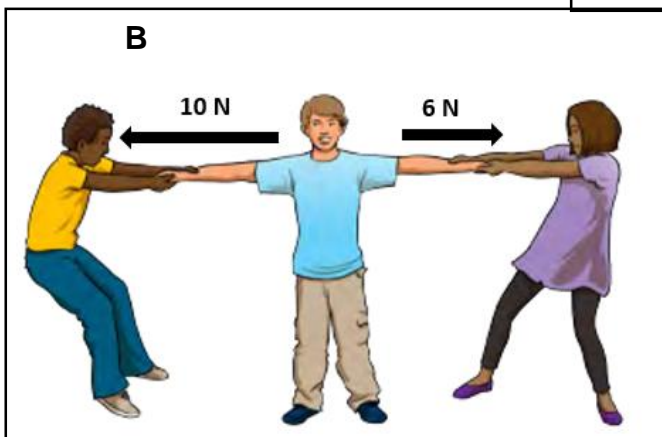
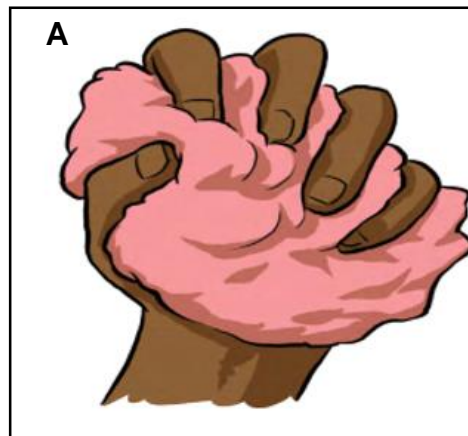

7.1 Give the definition of a force.

(1)

7.2 Calculate the net force and state the direction (left or right) of the net force in each of the diagrams B and C.

(2)

7.3 Give the specific name of the force shown in diagram A.

(1)

7.4 The diagram below shows all the forces acting on the go cart in diagram C.

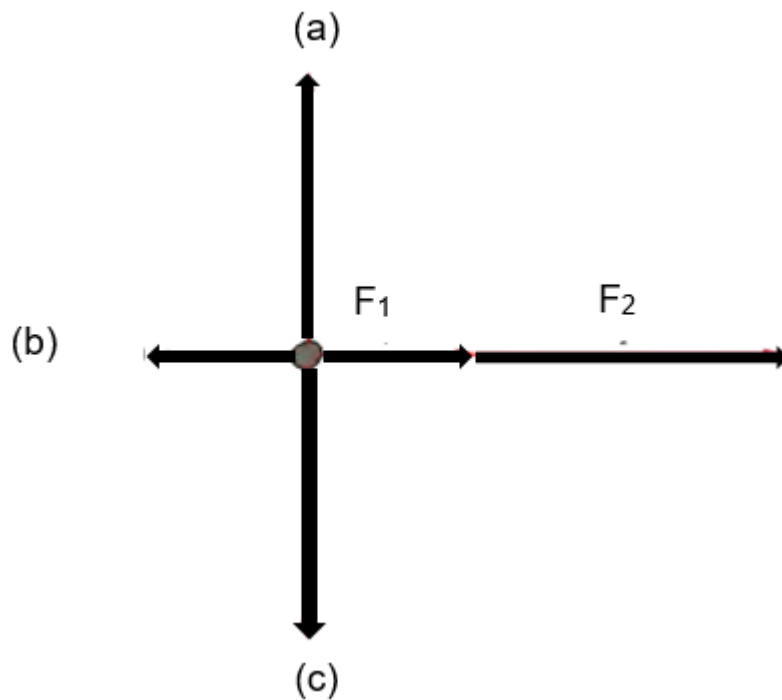

Provide the names of the specific forces labelled b and c.

(b) _____

(c) _____

(2)

7.5 Give TWO effects that a force can have on an object.

(2)

[8]

QUESTION 8

Joanna the astronaut performs an experiment to determine the relationship between mass and weight on different planets in our solar system. She sets off in a space ship and measures her own weight on the different planets. The following table shows her results.

Planet	Weight (N)
Mercury	192.5
Jupiter	1424.5
Earth	550
Moon	88

8.1 Using the information in the table, calculate the acceleration due to gravity (g) on Jupiter

[4]

QUESTION 9

A block with a weight of 1350 N is hoisted (lifted) vertically upwards from the ground by a chain winch and reaches a height of 2 m in 20 seconds.

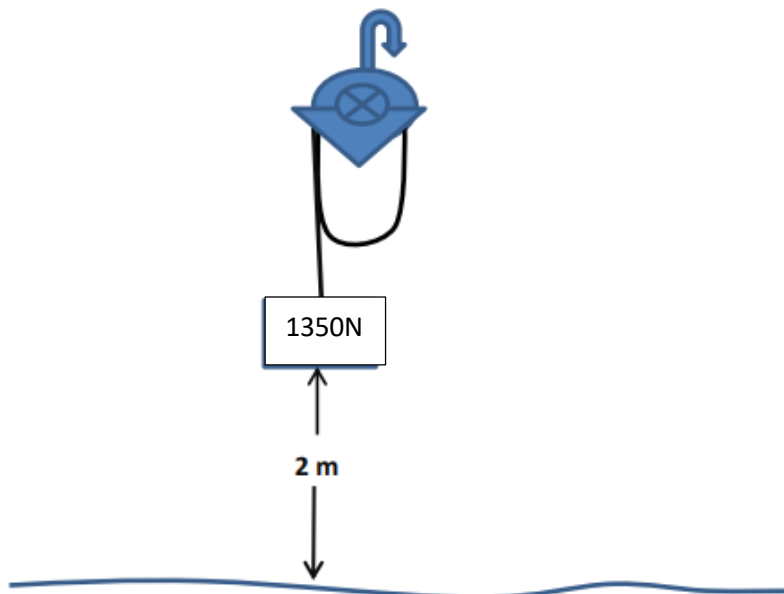

9.1 Calculate the power of the winch.

[6]

QUESTION 10

A man who has a mass of 80 kg is running away from a pit bull at a velocity of $5 \text{ m}\cdot\text{s}^{-1}$ and wants to jump over the garden wall that is 2 m high.

Using kinetic energy and potential energy calculations decide whether the man would be able to jump over the 2 m high wall. Round your answer off to 2 decimal places

[5]

GRAND TOTAL: 60