



NATIONAL SENIOR CERTIFICATE EXAMINATION  
NOVEMBER 2022

**ELECTRICAL TECHNOLOGY: ELECTRONICS**  
**MARKING GUIDELINES**

Time: 3 hours

200 marks

---

**These marking guidelines are prepared for use by examiners and sub-examiners, all of whom are required to attend a standardisation meeting to ensure that the guidelines are consistently interpreted and applied in the marking of candidates' scripts.**

**The IEB will not enter into any discussions or correspondence about any marking guidelines. It is acknowledged that there may be different views about some matters of emphasis or detail in the guidelines. It is also recognised that, without the benefit of attendance at a standardisation meeting, there may be different interpretations of the application of the marking guidelines.**

---

## GENERAL

- All marking is done by the marker in red.
- The marker may not make any corrections on the candidate's Answer Book.
- The memorandum serves as a guideline only.
- Alternative answers must be considered.
- A tick "✓" must be placed at each correct answer for which a candidate receives a mark.
- A cross "x" must be placed at each answer that is wrong.
- Calculations are marked as follows, unless stated otherwise:
  - 1 mark is awarded for the formula.
  - 1 mark is awarded for the substitution.
  - 1 mark is awarded for the answer with the correct applicable unit shown.
  - If the unit is indicated incorrectly, the answer is marked as wrong.
  - If an incorrect answer has to be used in the subsequent calculation, it is taken as correct in that calculation and the answer of the relevant calculation must be recalculated by the marker and marked accordingly. An arrow must be inserted from the incorrect answer to the subsequent calculation where substitution has been done with the incorrect answer to show that the incorrect answer has been taken into consideration.
- Sketches are marked by awarding 1 mark for the drawing if it was drawn correctly and all the other marks are awarded for the correct labels.
- See also the marking notes at relevant answers.
- A line must be drawn through all work that is not applicable to the answer, for example rough work.
- A diagonal line must be drawn through the space for questions that the candidate left open.
- A diagonal line must be drawn through all pages of the Answer Book that were not used by the candidate.
- A horizontal line must be drawn by the marker at the end of each question to indicate the end of the question.
- The marks for each question are written in a circle on the left-hand side at the beginning of the relevant question.
- The mark allocations for answers are written on the right-hand side of the page below one another. No circles are made around these marks.
- This memorandum consists of 13 pages.

**QUESTION 1      MULTIPLE-CHOICE QUESTIONS**

- 1.1    B
- 1.2    C
- 1.3    D
- 1.4    D
- 1.5    C
- 1.6    D
- 1.7    A
- 1.8    C
- 1.9    D
- 1.10   B
- 1.11   C
- 1.12   D
- 1.13   C
- 1.14   B
- 1.15   C

**QUESTION 2      SAFETY**

- 2.1    User refers to the person who uses tools or equipment for his/her own benefit and who is in control of tools or equipment.
- 2.2    An unsafe condition is the defects or shortcomings in the workplace that may lead to an accident.
- 2.3
  - The manufacturer should provide a manual for the equipment that explains how to use the equipment correctly and safely.
  - The manufacturer should make sure that the equipment is supplied safe for work to the consumer.
  - The manufacturer installing or erecting equipment should make sure that the equipment is safe when it is used correctly.
- 2.4
  - The employee should report any defects or shortcomings to the safety representative or the accountable person as soon as possible.
  - The employee should report any accident in which he/she is involved to the employer as soon as possible.

**QUESTION 3 RLC**

- 3.1
- The capacitive reactance doubles,
  - because the capacitive reactance is inversely proportional to the frequency of the circuit.

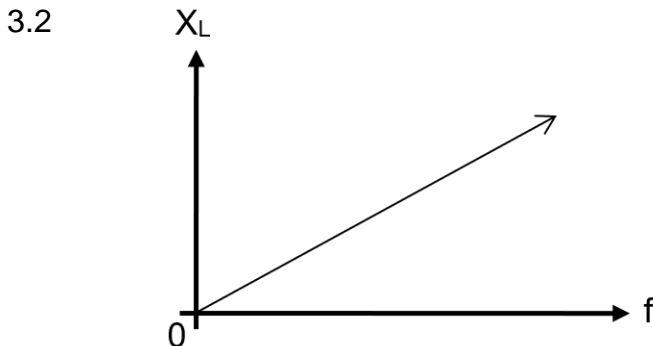

3.3 Impedance refers to the total alternating-current resistance of an RLC circuit.

3.4 Bandwidth refers to the number of frequencies where an RLC circuit displays resonant properties.

3.5 3.5.1  $X_L = 2\pi fL$   
 $X_L = 2\pi 22k \times 10m$   
 $X_L = 1,382 \text{ k}\Omega$

3.5.2  $X_C = \frac{1}{2\pi fC}$   
 $1,382k = \frac{1}{2\pi 22kC}$   
 $C = 5,233 \text{ nF}$

3.5.3 Q factor =  $\frac{V_C}{V_T}$   
 Q factor =  $\frac{221,12}{24}$   
 Q factor = 9,213

**OR**  $Q = \frac{1}{R} \sqrt{\frac{L}{C}}$   
 $Q = \frac{1}{150} \sqrt{\frac{10m}{5,233n}}$   
 $Q = 9,215$

**OR**  $Q = \frac{X_L}{R}$   
 $Q = \frac{1,382k}{150}$   
 $Q = 9,213$

3.5.4  $Z = R = 150 \Omega$

3.6 3.6.1  $I_T = \sqrt{I_R^2 + I_X^2}$   
 $I_T = \sqrt{60m^2 + 40m^2}$   
 $I_T = 72,111 \text{ mA}$

3.6.2  $\cos \theta = \frac{I_R}{I_T}$   
 $\cos \theta = \frac{60m}{72,111m}$   
 $\cos \theta = 0,832$   
 $\therefore \theta = 33,69^\circ \text{ lagging}$

3.6.3  $I_X = I_L - I_C$   
 $40m = I_L - 120m$   
 $I_L = 160 \text{ mA}$

3.7

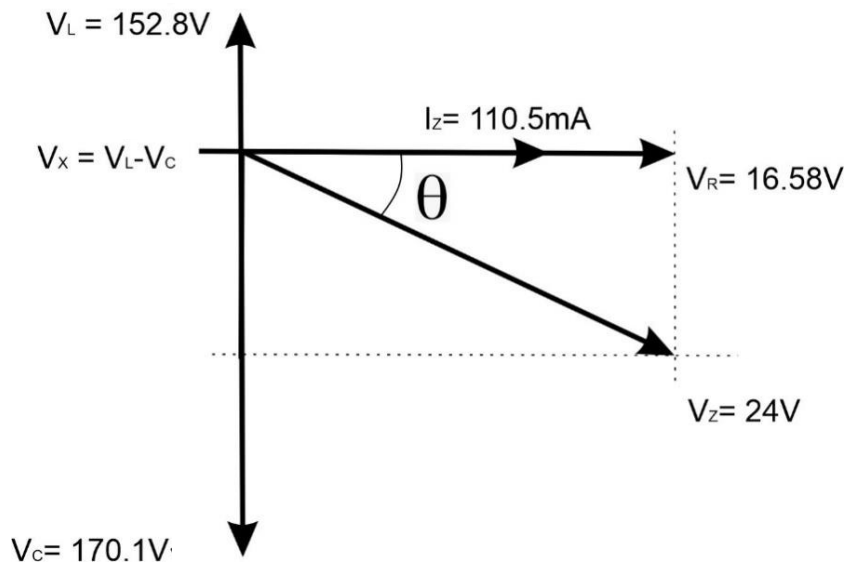

**Marking note**

- A mark is awarded for the line with correct value shown.
- Phase angle is only indicated to receive mark.

**QUESTION 4 SEMICONDUCTORS**

4.1

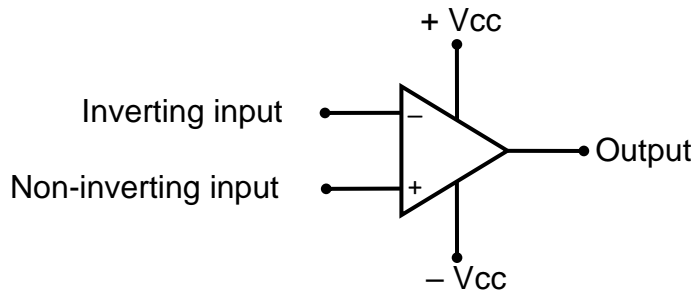

4.2 The voltage supply provides three connection points, namely a positive voltage, an earth terminal or zero-voltage terminal and a negative voltage connection point.

$$4.3 \quad V_o = -\frac{R_f}{R_i} V_i$$

$$8,5 = -\frac{R_f}{180} \times 10m$$

$$R_f = 153 \text{ k}\Omega$$

**Marking note**

- The negative may be left out in the answer, because resistance cannot be negative. It indicates only the nature of the feedback.

4.4 4.4.1 Threshold-voltage terminal

4.4.2 Trigger terminal

4.5 Create a voltage-divider circuit to divide the supply voltage in three equal voltages. One voltage of  $1/3 V_{cc}$  is applied to the one comparator as a trigger reference voltage and the other voltage of  $2/3 V_{cc}$  is applied to the other comparator as a threshold voltage.

4.6 The trigger terminal (active low-voltage terminal) compares the voltage with the reference voltage of  $1/3 V_{cc}$  to activate the RS flip-flop circuit when a voltage of less than  $1/3 V_{cc}$  is present on the trigger terminal.

4.7 4.7.1 Source

4.7.2 Gate

4.7.3 Output

4.7.4 Channel

**Marking note**

- The source and the output cannot be swapped, because the depletion region at the output is indicated as greater as a result of the negative voltage that connects the PN junction under reverse bias and the polarity signs that are shown.

- 4.8
- When the unijunction transistor is connected to a voltage supply, a voltage drop will develop across the length of the component.
  - Two voltage drops are distinguished, namely the voltage drop across base 1 and the emitter, and the voltage drop across the emitter and base 2.
  - The voltage drop across the emitter and base 2 is known as the specific voltage.
  - When an external voltage that exceeds the specific voltage is applied to the component's emitter,
  - the internal resistance of the component will drop very quickly
  - and the component will start conducting between base 1 and base 2.
  - When the emitter voltage is removed, the internal resistance of the component will increase very quickly
  - and the component will react like an open switch.

4.9

$$V_o = V_i \left( 1 + \frac{R_f}{R_i} \right)$$

$$V_o = 150m \left( 1 + \frac{33k}{1,5k} \right)$$

$$V_o = 3,45 \text{ V}$$

4.10 4.10.1

$$A_v = \frac{R_f}{R_i}$$

$$A_v = \frac{2,8k}{5,6k}$$

$$A_v = 0,5$$

- 4.10.2
- The output signal will remain unchanged,
  - because the value of the output signal is determined by the gain of the circuit and not by the supply voltage of the circuit.

4.11 4.11.1 Non-inverting amplifier

4.11.2

$$V_o = V_i \left( 1 + \frac{R_f}{R_i} \right)$$

$$4,275 = 150m \left( 1 + \frac{33k}{R_2} \right)$$

$$R_2 = 1,2 \text{ k}\Omega$$

4.11.3 The output voltage of the circuit will more or less double.

**QUESTION 5 SWITCHING AND CONTROL CIRCUITS**

5.1

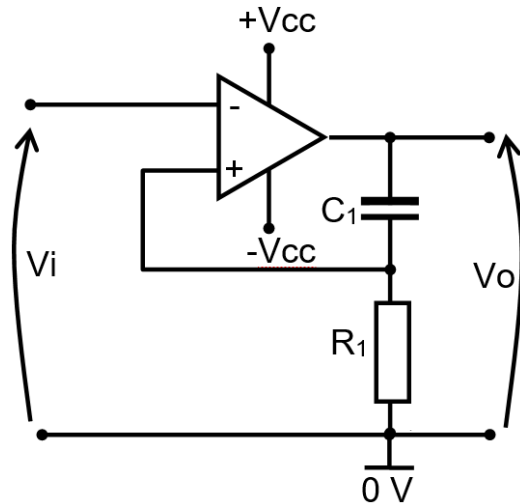

**Marking note**

- 1 mark for the correct 741 IEC symbol with all labels.
- 1 mark for the correct connection of the feedback capacitor.
- 1 mark for the correct connection of the reference resistor.
- 1 mark for the correct connection of the feedback conductor.
- 1 mark for the correct indication of the 0 V conductors.

5.2 5.2.1 Resistors  $R_1$  and  $R_2$  form a voltage-divider network to form a reference voltage across resistor  $R_1$  with which the incoming signal can be compared.

5.2.2 The incoming signal will be amplified maximally out of phase. The output voltage of the circuit now tends to be positive and, as a result, will switch on the red LED and the green LED will switch off.

5.3 
$$V_o = -\left(\frac{R_f}{R_1} V_1 + \frac{R_f}{R_2} V_2 + \frac{R_f}{R_3} V_3\right)$$

$$V_o = -\left(\frac{180k}{1,8k} \times 10m + \frac{180k}{2,2k} \times 15m + \frac{180k}{4,7k} \times (-12m)\right)$$

$$V_o = -2,181 V$$

5.4 
$$T = 0,693RC$$

$$T = 0,693 \times 680k \times 12n$$

$$T = 5,654 ms$$

5.5 5.5.1 Differentiating circuit/Differentiator

5.5.2

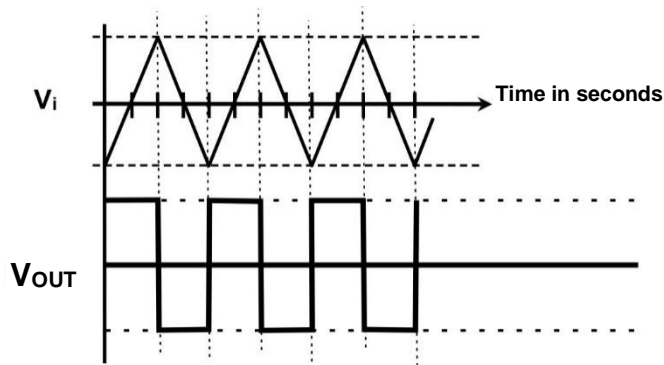

**Note:**

- Input signal is fed to inverting input of amplifier. Thus the polarity of the output voltages.

5.6 5.6.1 Astable multivibrator

$$T_{ON} = 0,693(R_1 + R_2)C_1$$

$$T_{ON} = 0,693(10k + 47k) \times 33\mu$$

$$T_{ON} = 1,303 \text{ s}$$

- 5.6.3
- The capacitor charges
  - through resistors  $R_1$  and  $R_2$  at the RC time constant.
  - When the voltage across the capacitor is more/higher than the threshold voltage,
  - the 555 timer reacts to the voltage across the capacitor.
  - The output of the 555 timer will now switch from high to low to
  - switch off the LED.

**Marking note**

- Answer is in bulleted list format to facilitate marking.

- 5.6.4
- Together with resistor  $R_1$ , resistor  $R_2$  determines
  - the charging rate of the capacitor in the circuit ( $T_{ON}$ ).
  - Resistor  $R_2$  also determines the discharge rate ( $T_{OFF}$ ) of the capacitor in the circuit.

5.7 5.7.1

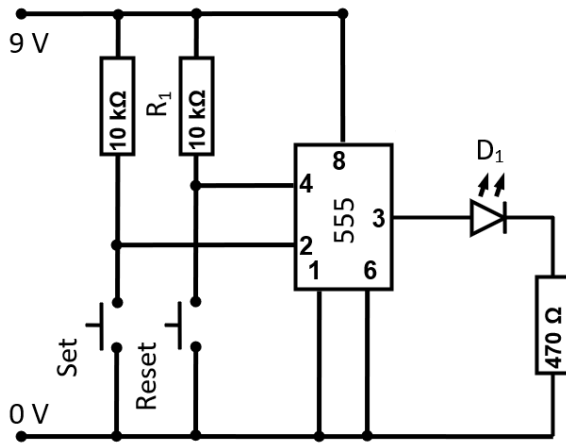

**Marking note**

- 1 mark for each component that is connected and labelled correctly.

5.7.2

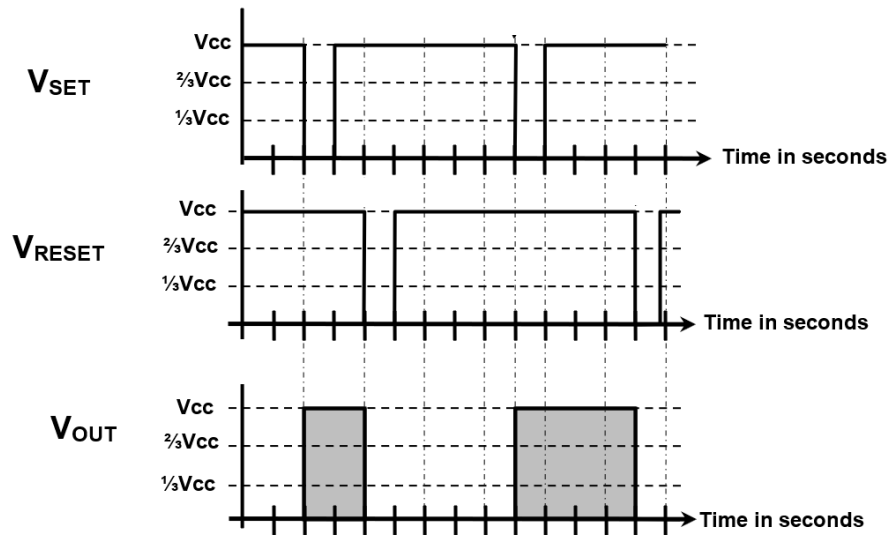

**Marking note**

- The fifth mark is for the waves that are drawn up to 0 V.
- The length of the pulse on 0 V is not important, it just may not exceed the reset or set pulse's 0 V pulse.

5.7.3

- When the set switch is pressed,
- the voltage on the trigger input of the 555 timer is pulled down to less than  $1/3V_{cc}$ .
- The output of the 555 timer will now tend to be high and remain high.
- When the reset switch is pressed,
- the voltage on the reset input of the 555 timer is pulled low and the 555 timer will react to this and the output will tend to be low.

**Marking note**

- Answer is in bulleted list format to facilitate marking.

**QUESTION 6      AMPLIFIERS**

6.1    6.1.1     $I_C = \frac{V_{CC}}{R_C}$  provided  $V_{RC} = 0 V$

$$I_C = \frac{12}{470}$$

$$I_C = 25,531 \text{ mA}$$

6.1.2     $V_{CE} = V_{CC}$  provided  $I_C = 0 A$

$$\therefore V_{CE} = 12 V$$

6.1.3     $I_B = \frac{V_{CC} - V_{BE}}{R_B}$

$$I_B = \frac{12 - 0,7}{120k}$$

$$I_B = 94,166 \mu A$$

6.1.4

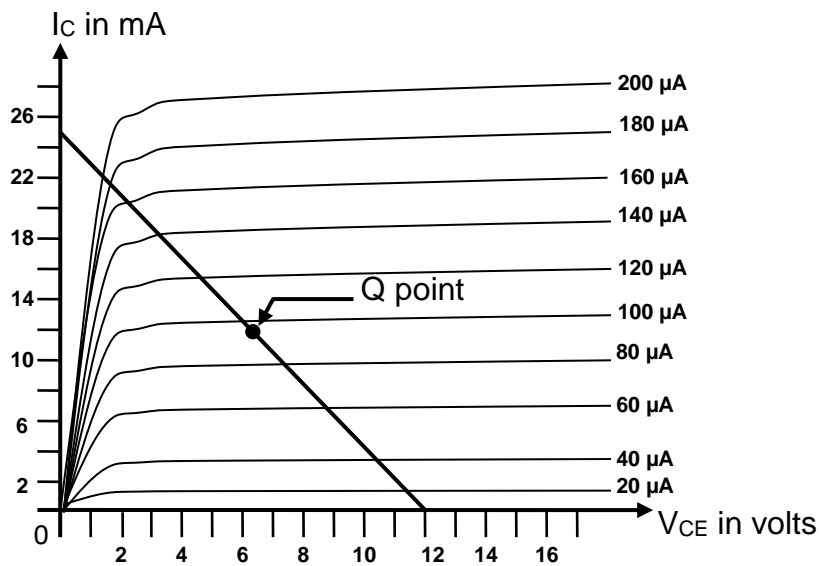

- 6.2
- Reduces noise and distortion of the output wave.
  - Improves the gain stability of the circuit.
  - Increases the bandwidth of the circuit.
  - Increases the input and output impedances of the circuit.

6.3

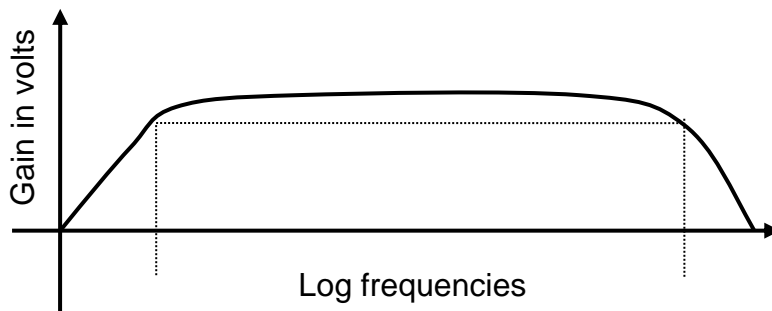

6.4  $A_v = 20 \log \frac{V_o}{V_i}$   
 $A_v = 20 \log \frac{3,5}{250m}$   
 $A_v = 22,922 \text{ dB}$

6.5 As the input frequency of the circuit rises, the capacitive reactance of the capacitors in the circuit will drop and the inductive reactances of the inductors in the circuit will rise. The closer the reactances move to each other, the closer the circuit becomes to the resonant frequency. As the circuit moves more into resonance, the voltage gain across the inductor in the circuit will increase immensely at point A to remain true to RLC resonant principles. The increase in resonant voltage gain across the coil explains the increase in gain at specific frequencies. When the frequency of the incoming signal rises above the circuit's resonant frequency, the voltage gain across the inductor will drop quickly and the gain of the circuit, therefore, also drops.

6.6 When an input signal is applied to the base of the transistor, the transistor will react to this and the current flow through the collector-emitter of the transistor will increase and decrease depending on the signal's frequency on the base of the transistor. The transformer's primary coil is connected in series with the transistor's collector and, therefore, the transistor regulates the current flow through the primary coil of the transformer. The current flow through the primary coil of the transformer will now cause a voltage drop across the primary coil of the transformer. The transformer will transform this voltage and make it available as an amplified voltage on the secondary coil of the transformer.

$$6.7 \quad 6.7.1 \quad fr = \frac{1}{2\pi\sqrt{6RC}} \quad \text{OR} \quad fr = \frac{1}{2\pi RC\sqrt{2N}}$$

$$fr = \frac{1}{2\pi\sqrt{6 \times 10k \times 10n}} \quad fr = \frac{1}{2\pi \times 10k \times 10n\sqrt{2 \times 3}}$$

$$fr = 6,497 \text{ Hz} \quad fr = 649,747 \text{ Hz}$$

**Marking note**

(Formula is incorrect, but is included in the memorandum to provide for the formula that is supplied in the prescribed textbook.)

- 6.7.2 When the circuit switches on, the transistor will switch on to allow the q-cent base current to flow. As a result, a decrease in voltage develops on the collector of the transistor because of the increase in the collector-emitter current flow through the transistor. This decrease in collector voltage is connected via capacitor C1 to the RC resistor network as a positive feedback. Each RC network will cause a phase shift of 60°. The result is that when the signal has passed through the three RC networks, the signal has gone through a total phase shift of 180°. Therefore, the initial decrease in voltage will now be an increase in voltage on the base of the transistor. This increase in voltage will cause more forward bias in the transistor and as a result will switch on the transistor maximally. When the transistor is switched on maximally, no further feedback of collector-voltage takes place. Therefore, the transistor will now move back to the q-cent value of the circuit. The result is that the voltage on the collector of the transistor starts rising. The increase in collector voltage will now go through a phase shift of 180° through the RC network to provide a decrease in the base-emitter voltage of the transistor. There will now be less forward bias in the transistor and a decrease in collector voltage will be observed. When the capacitors are fully charged, no further positive feedback will take place and the process repeats itself, in this way generating a varying output voltage.

**Marking note**

The supplied answer is very elaborate and complete. This has been done to provide the marker with a full picture of the operation to ensure that the marker is able to mark all possible answers. The marker should read the answer of the candidate and evaluate it using the given marking guideline. The candidate has to provide eight facts regarding the operation of the circuit to receive maximum marks.

**Total: 200 marks**